



# Optimal Placement of TCSC and DPFC on Nigeria Power Transmission Network for Capacity Enhancement

Diligent Onuoma Amahia <sup>a\*</sup> and Patrick Oshevire <sup>a</sup>

<sup>a</sup> Department of Electrical and Electronics Engineering, Federal University of Petroleum Resources, Effurun Delta State, Nigeria.

## Authors' contributions

This work was carried out in collaboration between both authors. Author DOA designed the study, developed the algorithm, wrote the code, and wrote the first draft of the manuscript. Author PO managed the analyses of the study, managed the literature searches. Both authors read and approved the final manuscript.

## Article Information

DOI: <https://doi.org/10.9734/jerr/2024/v26i111325>

## Open Peer Review History:

This journal follows the Advanced Open Peer Review policy. Identity of the Reviewers, Editor(s) and additional Reviewers, peer review comments, different versions of the manuscript, comments of the editors, etc are available here: <https://www.sdiarticle5.com/review-history/126167>

**Original Research Article**

**Received: 02/09/2024**

**Accepted: 04/11/2024**

**Published: 09/11/2024**

## ABSTRACT

The increasing demand for electrical energy and the high costs and challenges associated with building new transmission lines highlight the need to optimize existing power transmission networks. This study focuses on optimizing or enhancing Nigeria's 28-bus power transmission system using Flexible Alternating Current Transmission System (FACTS) devices, specifically, Dynamic Power Flow Controller (DPFC) and Thyristor-Controlled Series Compensator (TCSC). This research employed the Bacterial Foraging Optimization Algorithm (BFOA) in MATLAB to determine the optimal placement and sizing of DPFC and TCSC to minimize power losses, voltage deviations, and installation costs. Simulation results were compared, before and after incorporating the FACTS devices. In the base case, 32% of the buses had voltage profiles outside the acceptable

\*Corresponding author: Email: [diligent.amahia@gmail.com](mailto:diligent.amahia@gmail.com);

range (0.95 to 1.05 p.u.), with real power loss of 602.91 kW and reactive power loss of 4559.69 kVAR. After optimally placing two DPFC and two TCSC devices in the system, all bus voltages were regulated to fall between 0.95 and 1.06 p.u., while real and reactive power losses were reduced by approximately 84.6% and 84.7%, respectively. This demonstrates a significant improvement in the efficiency and capacity of the power transmission network.

*Keywords: Dynamic power flow controller; thyristor controlled series compensator; optimal placement; optimal flow; voltage profile.*

## 1. INTRODUCTION

Electric power system is a compact system of three major components known as generation, transmissions, and distribution systems. To meet customers' demand, the generation capacity is normally increased by expanding the existing system facilities to correspond to load growth. However, it is a well-known fact to utility operators and consumers that electric power systems all over the world are experiencing exponential rise in demand for regular power supply, thereby forcing power networks to be operated near their tolerance in which Nigeria is not exempted (Ebeed et al, 2018). For many years, the demand for power in Nigeria has increased greatly more than the generation capacity. The Nigeria government which was the sole producer of power was saddled with the responsibility to solve this problem. In year, 2010, Nigerian government unbundled Power Holding Company of Nigeria (PHCN) to privatize the generation and distribution ends of the power system, like other developed countries have done (Obiora, 2019). The ownership of transmission was retained by the government of Nigeria. Due to poor investment on transmission facilities, the capacity has been greatly limited. This has resulted in operating the power network close to tolerance which could jeopardize the system security if the inadequacy created is not properly handled (Umar, 2018). The drive to increase power production comes with its challenges, one of which is the severe limitation/overloading of the power transmission lines which is to carry the bulk power from the generating plants to the point of usage due to inadequate infrastructure and environmental restrictions (Melodi & Akinloye, 2014). Although, expansion of existing power networks and building of new ones will largely address the problem of increasing power demand, unfavorable policies of government, coupled with financial, environmental, and time factors are the major problems faced (Devabalaji and Ravi, 2015).

Currently, Flexible Alternating Current Transmission System (FACTS) devices are used to improve voltage profile and enhance transmission network's capacity. They are power electronics-based systems and other static equipment that provide control of one or more parameters of AC transmission system used to enhance controllability and power transfer capability. The functions of FACTS controllers are to improve voltage profile and reduce power losses, enhance power flow in critical lines within the operating margins, and provide auxiliary stabilizing controllers to damp oscillations of low frequency thereby enhancing the steady state stability region (Padjyar, 2007). FACTS devices also increase transient stability limit thereby improving dynamic security of the power system and reducing the incidence of blackouts caused by cascading outages, overcome problem of voltage fluctuations and dynamic overvoltage and counter the problem of Sub synchronous Resonance (SSR) but they must be placed optimally in the network.

There are several approaches used for optimal placement of FACTS devices in power transmission network one of which is the Classical approach (Araga et al., 2017). In (Besharat and Tahar, 2008) a sensitivity method based on real power performance index and reduction of overall network loss was reported. Many meta-heuristic approaches such as Genetic Algorithm in (Duraisamy and Ponnusamy, 2017), Particle Swarm Optimization Algorithm in (Chakravarthy and Vaisakh, 2017), Fuzzy Logic-Gravitational Search Algorithm in (Farsangi et al., 2017) Differential Evolutionary Algorithm in (Udgir et al., 2014), and Improved Harmonic Search Algorithm in (Sirjani et al., 2011) have been developed and used for optimal placement of FACTS devices in power transmission network for improving power system reliability and enhancing capacity. All of the above approaches recorded some level of success. However, there is still need for a more robust, faster, and more efficient approaches for optimal placement of FACTS devices such as

DPFC and TCSC in power transmission network for enhanced power system operation.

This paper presents a Bacterial Foraging Optimization Algorithm (BFOA) which is a new class of biologically inspired stochastic global search technique that is based on mimicking of the foraging behavior of *E. Coli* bacteria (Tomonobu et al, 2021). BFOA was proposed by (Passino, 2002) and it is one of the nature-inspired optimization algorithms. BFOA is known for its efficacy over other evolutionary and swarm computing algorithms in solving engineering optimization problems and consists of four prime steps, which includes: chemotaxis, swarming, reproduction, and elimination-dispersal. This paper explored BFOA to optimally size and locate DPFC and TCSC on Nigeria 28-bus network to minimize power losses and voltage deviation to enhance the capacity of the selected transmission network.

## 2. LITERATURE REVIEW

Power or load flow has been an essential part of power systems study. Research have been carried out to improve power transmission system of Nigeria using FACTS devices. This section presents a summary of related literature that is available regarding power system analysis using FACTS devices.

(Umar *et al.*, 2019) worked on Application of Bacterial Foraging Algorithm in the Allocation of Distributed Static Compensator (DSTATCOM) in 50-bus canteen feeder, Zaria, Kaduna State. Maintaining the system voltage within an acceptable limit was observed to be very useful in reducing power losses and improving the overall system operational capability. The authors noted the high losses experienced at the distribution end of power systems and it is becoming a major concern to power system operators, with about 10-13% of the total generation being dissipated as heat. The standard IEEE 33-bus test network's three-quarter (75%) loading condition was utilized to test the swarm-based meta-heuristic model before it was employed on the 50-bus Canteen feeder for both normal (100%) and three-quarter (75%) loading states. Both networks underwent thorough investigation, and the outcomes were contrasted with the corresponding base-case scenarios/conditions. With the allocation of DSTATCOM in both networks using the BFA based model, the evaluation's final results, which were acquired through simulation, demonstrated

a discernible improvement in overall voltage profile and decrease in power losses.

(Apribowo *et al.*, 2018) worked on Optimal Power Flow with Optimal Placement of Thyristor-Controlled Series Compensator (TCSC) on 500 kV Java-Bali Electrical Power System using GA-Taguchi Method. Java-Bali is in Indonesia. They demonstrated how optimal power flow with optimal placement and rating of TCSC can be a solution to the high cost of operating a power plant. They used the genetic algorithm-design of experiment technique (GA-DOE) to determine the optimal placement and rating of TCSC to reduce total cost of power generation. To verify the method, a simulation was done on 500 kV Java-Bali power system. Different numbers of the compensator were used for the simulation. With 5 compensators, the method reduced the cost of generation by 0.89% compared to Optimal Power Flow without TCSC.

Placement of Fault Current Limiters in a Power System Through a Two-stage Optimization Approach was the focus of (Yang *et al.*, 2017). The study used a two-stage placement technique, with stage 1 combining the Hashing-integrated generic algorithm (HIGA) and hierarchical fuzzy logic decision (HFLD) method. The HIGA selected the best location for FCL in the condensed search space, and the HFLD approach was utilized to identify or sort feasible solution. Then, in Stage II, PSO was used to optimize the fault current limiters' (FCLs) settings. This was in an effort to position FCLs in power networks appropriately and realize the best cost-benefit ratio. The efficiency of the suggested method for resolving the optimal FCL placement problem was tested using the IEEE 30-bus system and the system of a Taiwanese manufacturing facility. The findings demonstrated that the suggested strategy was successful with fewer installations of fault current limiters and quickly arrived at a satisfactory resolution.

(Guo & Xian, 2013) investigated the best way to use a multi-objective estimation of distribution algorithm (MEDA) based on bacterial foraging for superconducting fault current limiter placement. Knowing that MEDA's weakness is an inadequate local search capacity, the researchers had to combine the algorithm with bacterial forging behavior to greatly enhance its performance. This work integrated MEDA-BF and the sensitivity coefficient of all branches during a short circuit failure in the power network or system, and it then proposed a superb set-

up/method that allows the use of a smaller number of superconducting FCLs while still being more economical. The sensitivity coefficient of all branches in the power network were calculated, and then, candidate branches based on their sensitivity coefficients were chosen. Finally, MEDA-BF applied for optimal allocation of SFCL with the number and economics of installation of SFCL as objective functions. To investigate the feasibility and reliability of MEDA-BF, computer simulation was done on the IEEE 30-bus test system on MATLAB software. MEDA-BF was found to have good convergence and diversity.

(Rehtanz *et al.*, 2011) also presented a hardware model or version of DPFC which was built at TU Dortmund University. The hardware model was downscaled by a factor which is a ratio of 1000 to a nominal phase-to-phase voltage of 380 V. The hardware model was used on a test transmission network for examination on evaluation of DPFC model parameters, design and implementation of DPFC controller, deployment of protection devices, and analysis of dynamics of the DPFC.

### 3. MATERIALS AND METHODS

The program for implementing the BFOA based technique under this study was coded in MATLAB R2022a virtual environment. Then, Nigeria 28-bus network line and bus data collected from National Control Center (NCC) were loaded. The base-case load flow analysis was performed to investigate voltage profile of the buses and line losses. The BFOA parameters in Table 1 were then initialized and the multi-objective function for use in the BFOA was formulated and applied. Then, the load flow analysis with the optimal sizes of DPFC and TCSC installed at the optimal locations was done and the improved voltage magnitudes at each bus and the corresponding results for reduction of line losses were displayed.

### 3.1 Description of Nigeria 28-Bus Network

This bus system of Nigeria transmission network transmits power at voltage of 330kV. It consists of nine (9) generator bus and nineteen (19) load bus having its control center at Oshogbo. The system is divided into three (3) major regions: North, South-West and South-East regions. The northern part of Nigeria is connected to the south by double circuit lines between Oshogbo and Jebba, whereas West is connected to the East via a double circuit line from Ikeja to Benin and one transmission line from Oshogbo to Benin. It is operated and managed by Transmission Company of Nigeria. The single- or one-line diagram of this network under study is shown in Fig. 1.

### 3.2 Formulation of Objective Function

Optimization technique is an important approach in the aim to obtain the most suitable location and sizing of FACTS devices. Some of the objectives of installing TCSC and DPFC in power systems is to minimize power losses and bus voltage deviations. The cost of installation of the selected FACTS devices has also been considered in this paper. In this study, BFOA has been chosen because of its capability to achieve optimal solution and ease of convergence.

The multi-objective function,  $F$  is stated in Equation (1):

$$F = \min(F_1 + F_2 + F_3 + F_4) \quad (1)$$

Where  $F_1$  = Real power loss,

$$F_2 = \text{Voltage deviation}$$

$$F_3 = \text{COST}_{DPFC}$$

$$F_4 = \text{COST}_{TCSC}$$

**Table 1. BFOA Parameters**

BFOA Initialized Parameters	Value
Initial population of bacteria, $S$	4
Dimension of search space, $P$	3
Chemotactic steps, $N_c$	2
Swim steps, $N_s$	1
Reproductive steps, $N_{re}$	2
Elimination and dispersal steps, $N_{ed}$	2
Step size, $C(i)$	0.1
Elimination and dispersal probability of bacteria, $P_{ed}$	0.9

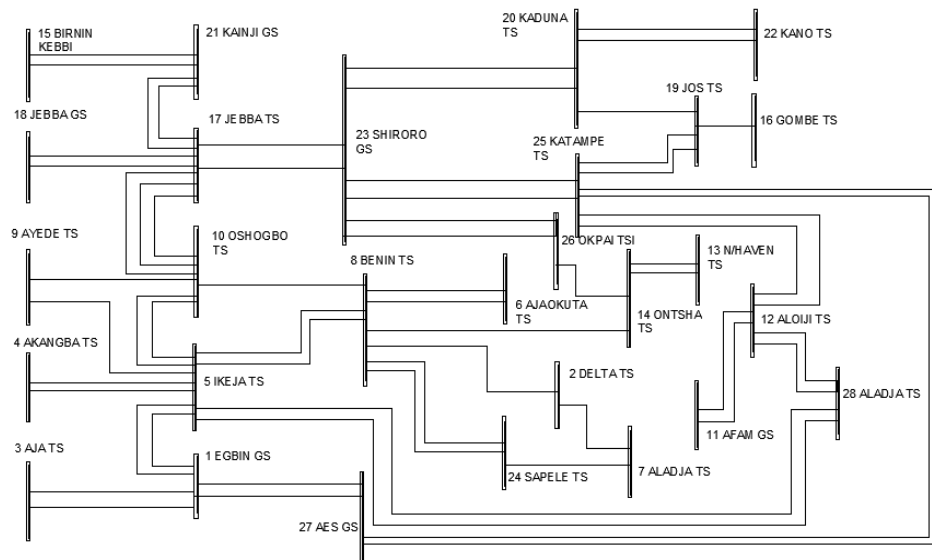

Fig. 1. Single Line Diagram of Nigeria 330kV 28-Bus Network (National Control Center)

Table 2. Nigeria 28-Bus Network Bus Data (NCC)

Bus No	Bus Code	Voltage Magnitude	Voltage Angle	Load		Generator		Qmin	Qmax
				MW	MVar	MW	MVar		
1	1	1.050	0	68.9	51.7	0	0	-1006	1006
2	2	1.050	0	0	0	670	0	-1030	1000
3	0	1.000	0	274.4	205.8	0	0	0	
4	0	1.000	0	344.7	258.5	0	0	0	
5		1.000	0	633.2	474.9	0	0	0	
6	0	1.000	0	13.8	10.3	0	0	0	
7	0	1.000	0	96.5	72.4	0	0	0	
8	0	1.000	0	383.3	287.5	0	0	0	
9	0	1.000	0	275.8	206.8	0	0	0	
10	0	1.000	0	201.2	150.9	0	0	0	
11	2	1.050	0	52.5	39.4	431.0	0	-1000	1000
12	0	1.000	0	427.0	320.2	0	0	0	
13	0	1.000	0	177.9	133.4	0	0	0	
14	0	1.000	0	184.6	138.4	0	0	0	
15	0	1.000	0	114.5	85.9	0	0	0	
16	0	1.000	0	130.6	97.9	0	0	0	
17	0	1.000	0	11.0	8.2	0	0	0	
18	2	1.050	0	0.0	0.0	495.0	0	-1050	1050
19	0	1.000	0	70.3	52.7	0	0	0	
20	0	1.000	0	193.0	144.7	0	0	0	
21	2	1.050	0	7.0	5.2	624.7	0	-1010	1010
22	0	1.000	0	220.6	142.9	0	0	0	0
23	2	1.050	0	70.3	36.1	388.9	0	-1000	1000
24	2	1.050	0	20.6	15.4	190.3	0	-1000	1000
25	0	1.000	0	110.0	89.0	0	0	0	0
26	0	1.000	0	290.1	145.0	0	0	0	0
27	2	1.050	0	0.0	0.0	750.0	0	-1000	1000
28	2	1.050	0	0.0	0.0	750.0	0	-1000	1000

### 3.3 Minimization of Real Power Loss

In this phase, the minimization of the active power loss is realized. The preliminary objective function involving the significant reduction of the actual power loss in power transmission lines is effectively illustrated by Equation (2).

$$F_1 = P_{Loss} = \sum_{k=1}^{N_{line}} G_{kj} [V_k^2 + V_j^2 - 2V_k V_j \cos(\delta_k - \delta_j)] \quad (2)$$

where  $P_{Loss}$  represents the real power loss,  $N_{line}$  indicates the total number of power transmission lines,  $G_{kj}$  corresponds to the conductance between the bus  $k$  and  $j$ ,  $V_k$  and  $V_j$  symbolize the voltages of the bus  $k$  and  $j$ , and  $\delta_k$  and  $\delta_j$  represent angles of bus  $k$  and  $j$ .

### 3.4 Minimization of Voltage Deviation

The minimization of the variation in the voltage magnitude at load buses is performed as shown in Equation (3).

$$F_2 = V_{dev} = \sum_{i=1}^{N_L} |V_i - V_i^*| \quad (3)$$

where  $N_L$  stands for the number of load buses,  $V_i$  characterizes the nominal value of voltage magnitude,  $V_i^*$  indicated by reference value of the voltage magnitude at the  $i^{th}$  load bus and  $V_i^*$  is normally fixed as 1.0p.u.

### 3.5 Cost of FACTS Devices

The investment outlay representing the objective functions for DPFC and TCSC devices is evaluated in terms of United States dollar (US\$) by means of Equations (4) and (5) (Jumaat et al., 2012).

$$F_3 = Cost_{DPFC} = 0.0003S^2 - 0.026911S + 188.2227 \quad (4)$$

$$F_4 = Cost_{TCSC} = 0.0015S^2 - 0.7130S + 153.7 \quad (5)$$

where,

$$S = |Q2 - Q1|$$

$S$  = operating range of TCSC in (MVar)

$Q1$  = reactive power flow through the branch before FACTS installation.

$Q2$  = reactive power flow through the branch after FACTS installation.

### 3.6 Voltage Constraints

Equations (6) and (7) illustrate the limits on the voltage magnitudes at all the buses.

$$V_i^{min} \leq V_i \leq V_i^{max}, i = 1, 2, \dots, N_{bus} \quad (6)$$

$$V_j^{min} \leq V_j \leq V_j^{max}, i = 1, 2, \dots, N_{bus} \quad (7)$$

### 3.7 Bacterial Foraging Optimization Algorithm Structure

BFOA is a swarm-based and nature-inspired algorithm which was proposed or invented by Kevin Passino in 2002. The algorithm is developed to mimic the foraging (location, handling, and injection food) behavior of *Escherichia coli* bacteria found in the intestine (Umar, 2019). The algorithm is modeled based as shown in Fig. 2 based on four major processes/steps: chemotaxis step, swarming step, reproduction step as well as elimination-dispersal (Xing, 2014).

- **Chemotaxis:** This explains the movement of bacteria over a landscape of nutrients. The  $i$ th bacterium movement is explained by:

$$\theta^i(j+1, k, l) = \theta^i(j, k, l) + C(i)\phi(i) \quad (8)$$

where  $\theta^i(j, k, l)$  is  $i$ th bacterium position at  $j$ th chemotactic,  $l$ th is the dispersion-elimination step,  $k$ th is the reproductive,  $C(i)$  is the step size, and  $\phi(i)$  represents the  $j$ th step direction angle.

The fitness of the  $i$ th bacterium is determined according to its position represented by  $J=J(i, j, l)$ . The tumble of the bacteria is explained by the direction angle  $\phi(i)$  as:

$$\phi(i) = \frac{\Delta(i)}{\sqrt{\Delta^T(i)\Delta(i)}} \quad (9)$$

where  $\Delta$  indicates a vector in the random direction whose elements lie in  $[-1, 1]$ .

- **Swarming:** The attractive and repulsive effects of each bacterium are used as a medium of communication to other bacteria. Attractants are released by bacteria under stress conditions to stimulate bacteria to swarm or group together, while repellent are released to inform others to maintain a reasonable

interval from the bacterium under stress. The bacteria cell-to-cell signaling mechanism is given by:

$$J_{cc}(\theta, P(j, k, l)) = \sum_{i=1}^S J_{cc}(\theta \theta^i(j, k, l)) \quad (10)$$

Where  $J_{cc}(\theta, P(j, k, l))$  is the objective function value (fitness function) to be added to the actual objective function (to be minimized) to present a time varying objective function,  $S$  represents the total number or population of the bacteria,  $p$  is the number of variables to be optimized.  $\theta = (\theta_1, \theta_2, \dots, \theta_p)^T$  is a point in the  $p$ -dimensional search domain.

- **Reproduction:** The least healthy bacteria subsequently die while each of the healthier bacteria (those that yield lower value of the objective function) split asexually into two similar bacteria, which

are then placed in the same location. This helps to keep the swarm size or population constant.

- **Elimination-Dispersal:** The process of elimination-dispersal is executed after  $N_{re}$  reproduction steps in order to avoid being trapped in local optima. Each bacterium is subjected to the process of dispersal and elimination within the environment according to a probability ( $P_{ed}$ ). The number of elimination and dispersal steps is denoted by  $N_{ed}$ . Fig. 2 shows a flow chart for the BFOA.

BFOA was used for this study due its ability to produce fast and accurate convergence and its simplicity of implementation.

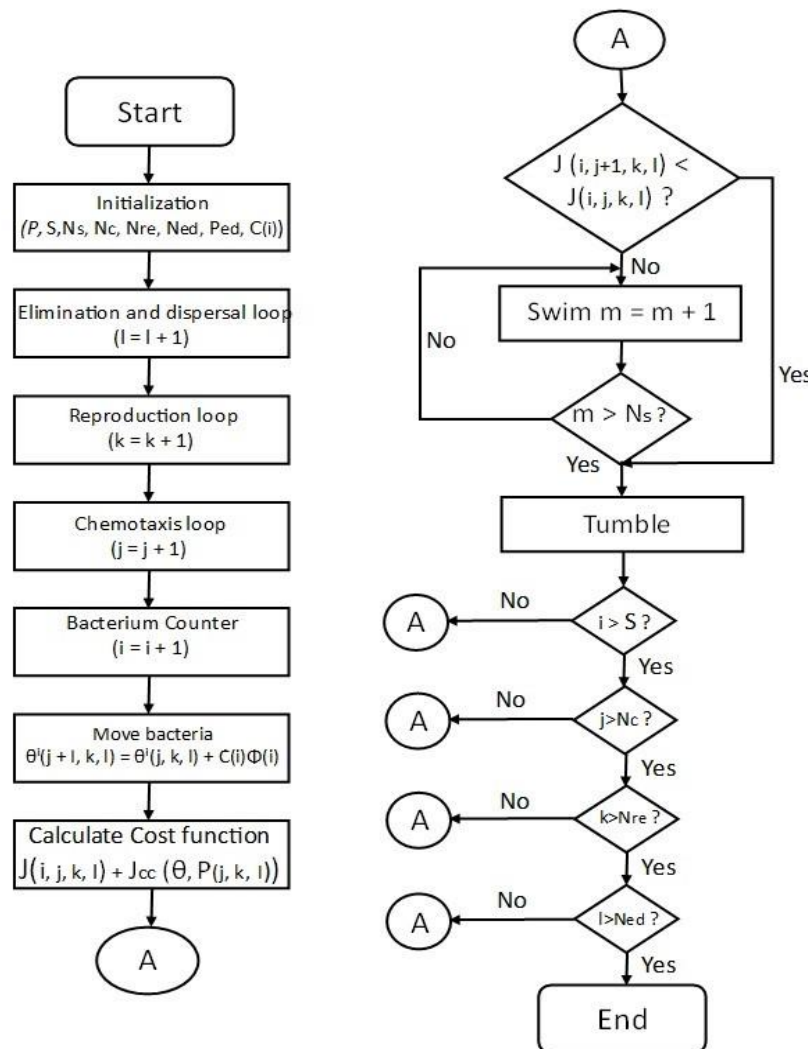

Fig. 2. Flow chart of Bacterial Foraging Optimization Algorithm

### 3. RESULTS AND DISCUSSIONS

From the load flow simulation of the network as seen in Figs. 3 and 6, about 32% of the buses (base case) had an abnormal voltage profile (either low or too high) since they completely fell out of the range of 0.95 - 1.05 p.u. The buses with low voltage magnitude include New Haven TS (0.84773), Onitsha TS (0.87082p.u.), and Gombe TS (0.93042). The buses having overvoltage magnitudes include: Kainji GS (1.082), Shiroro, Sapele, Alaoji, AES at 1.071pu each and Benin-Kebbi at 1.0673pu. The line flow results of the base-case as represented in Table 3 showed that the network had total real and reactive power losses of 602.91kw and 4559.69kVar respectively.

Figs. 3, 4, and 5 show the results of the simulation before and after DPFC was incorporated in the network to improve voltage profile and reduce losses respectively. Figs. 4 and 5 respectively show the graphical representation of the reduced real and reactive power losses on each line after the optimal placement of two DPFC in the network. The voltage magnitudes of the buses with low voltage profile were significantly improved and the buses with overvoltage magnitudes had their voltage regulated to the range of 0.95p.u. to 1.06p as illustrated in Fig. 3. With DPFC, the voltage magnitude at New Haven increase from 0.84773 to 0.95, Onitsha TS increased from 0.87082 to 0.9548p.u., and Gombe TS increased from 0.90501 to 0.95p.u. Total real power loss has

been reduced by 84.6% from 609.91kW to 92.53kW while total reactive power loss also reduced by 84.8% from 4559.69kVar to 694.87kVar as seen in Table 3. This considerable reduction of real and reactive power losses allows more power to be available on the lines thereby enhancing the capacity of the transmission system.

When TCSC was incorporated in the network, a similar result to DPFC was obtained as represented by Figs. 6-8. The voltage magnitudes at New Haven TS, Onitsha TS, and Gombe TS were significantly improved, while the buses with high voltage also had their voltage magnitude regulated to the range of 0.95p.u. to 1.06p.u as seen in Fig. 6. Total real power loss also reduced by 84.65% from 609.91kW to 92.544kW while total reactive power loss reduced by 84.64% from 4559.69kVar to 700.06kVar as seen in Table 3. Figs. 7 and 8 are the graphical representation of the real and reactive power losses respectively. This reduction in losses increases the power available on the power transmission network.

Table 3 summarizes the results of the simulation before and after incorporation of the selected FACTS devices. In the table, optimal placement of two DPFC are at bus 17 and 23, while that of TCSC are at bus 2 and 7. The cost of installation of the FACTS devices and their optimal sizes are also shown in the table. TCSC is found to be more expensive than DPFC as was expected.

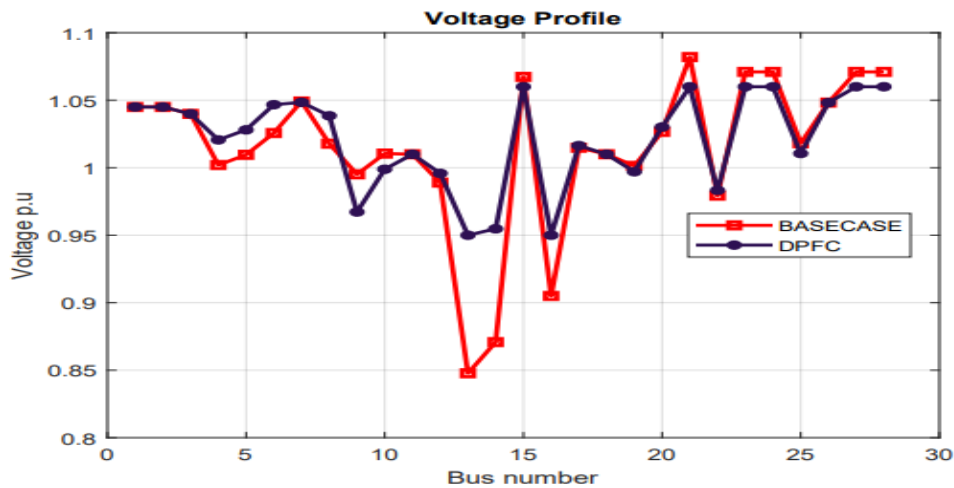

Fig. 3. Voltage Profile with and without DPFC



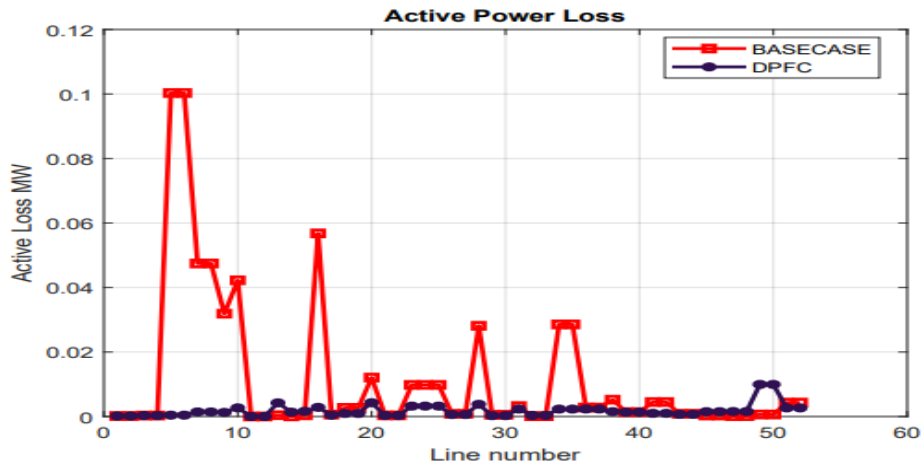

Fig. 4. Active Power Loss with and without DPFC

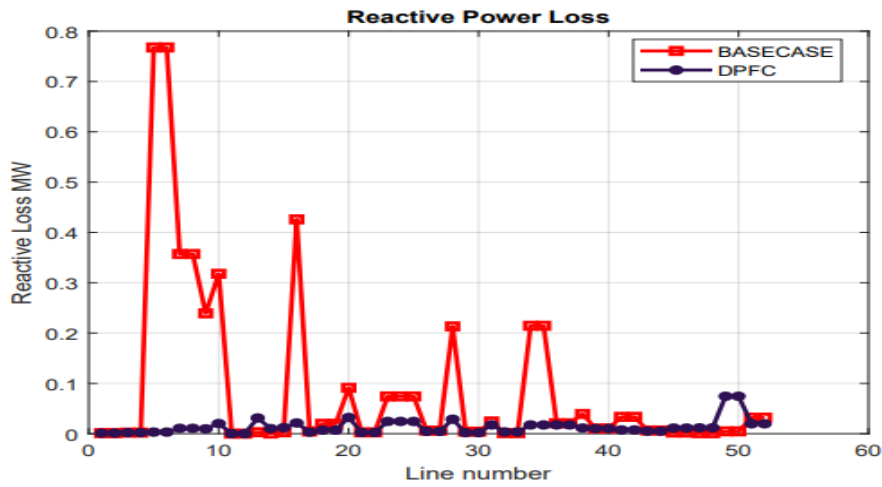

Fig. 5. Reactive Power Loss with and without DPFC

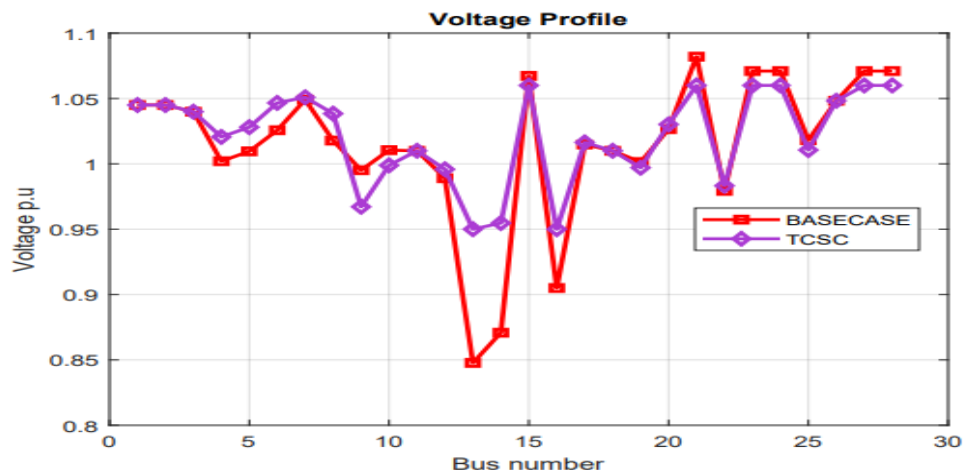

Fig. 6. Voltage Profile with and without TCSC

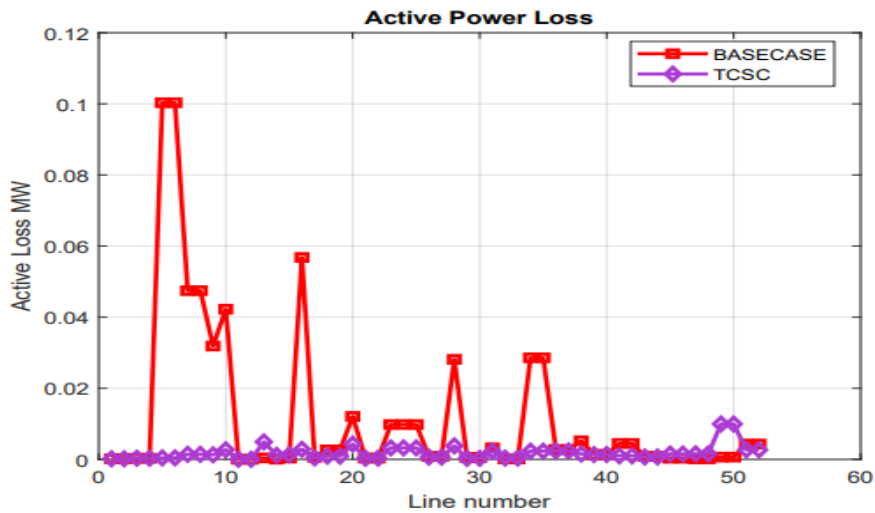

Fig. 7. Active Power Loss with and without TCSC

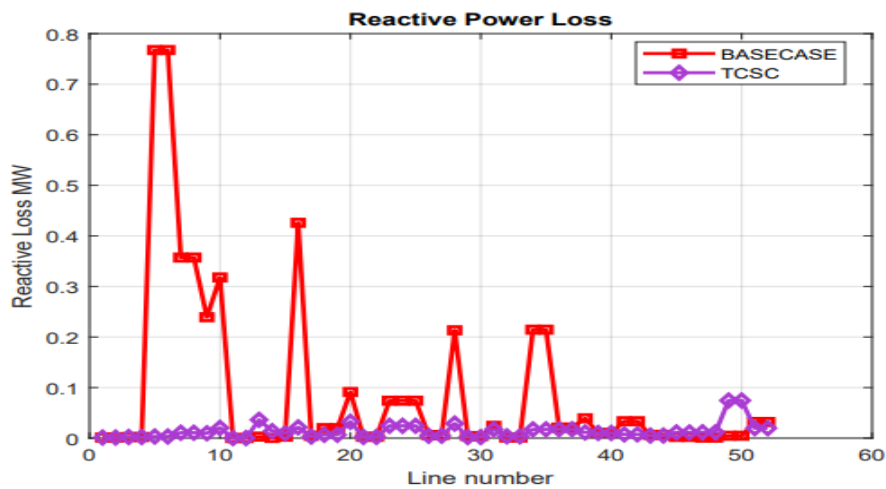

Fig. 8. Reactive Power Loss with and without TCSC

Table 3. Summary of results of incorporation of DPFC and TCSC

Devices	Active Power Loss(kW)	Reactive Power Loss(kVar)	Optimal Location of FACTS	Optimal Size of FACTS (kVar)	Cost of FACTS in US\$
Without FACTS	609.91	4559.69	-	-	-
With DPFC	92.531	694.87	Bus 17 and 23	60.03 and 41.51	3,629.2
With TCSC	92.544	700.06	Bus 2 and 7	14.26 and 14.00	19,746.8

#### 4. CONCLUSIONS

This paper has presented a bacterial foraging optimization algorithm approach for optimal placement of DPFC and TCSC in Nigeria

transmission network. The purpose was to enhance the capacity of the transmission system by minimizing power losses and bus voltage deviation. Simulation was done on the network to know the actual state of the system. Based on

the results of the base case load flow, an objective function consisting of power loss, voltage deviation, and cost of installation of the selected FACTS devices was formulated. From the results obtained, the following conclusions can be drawn:

- The 330kV power transmission network of Nigeria faces problem of instability of voltage with power losses.
- The optimal positions of DPFC in the network were discovered to be at bus 17 and 23 and the optimal sizes of DPFC were 60.03kVar and 41.51kVar respectively.
- The optimal positions (placement) of TCSC in the network were discovered to be at bus 2 and 7 and the sizes (optimal) of TCSC were 14.26kVar and 14.0kVar respectively.
- The costs of installation of DPFC and TCSC in US\$ were found to be 3,629.2 and 19,746.8 respectively.
- Optimal placement of the DPFC and TCSC using BFOA has made the power losses reduce by about 84% and voltage profile (bus) regulated to the range between 0.95pu and 1.06pu, thereby enhancing the power available on the transmission network.

#### DISCLAIMER (ARTIFICIAL INTELLIGENCE)

Author(s) hereby declare that NO generative AI technologies such as Large Language Models (ChatGPT, COPILOT, etc.) and text-to-image generators have been used during the writing or editing of this manuscript.

#### ACKNOWLEDGEMENTS

Firstly, my gratitude goes to God Almighty for the grace and provision all throughout the duration of this program. Special thanks to my amiable Project Supervisor, Engr. Dr. Patrick Oshevire for his support, guidance and supervision of this project work. I acknowledge the Acting Head of the Department, Engr. K.O. Enalume, Engr Dr. D.U. Onyishi, Dean of Engineering and Technology, Engr. Prof. Emovon Ikubaose, Engr. Dr. G.O Uzedhe, the Post Graduate Coordinator, Engr. Dr. B.O Akinloye, and other staff of the Department of Electrical and Electronics Engineering.

Also, I acknowledge my beloved wife, Mrs. Diligent, my Children, for the support,

encouragement and for availing me the peace of mind to concentrate on this work to the end.

#### COMPETING INTERESTS

Authors have declared that no competing interests exist.

#### REFERENCES

- Al Ahmad, A., & Sirjani, M. (2019). Optimal placement and sizing of multi-type FACTS devices in power systems using metaheuristic optimisation techniques. *Ain Shams Engineering Journal*, 3-4.
- Amarendra, A., Srinivas, L., & Srinivasa, R. (2022). Power system security enhancement in FACTS devices based on Yin-Yang pair optimization algorithm. Springer-Verlag.
- Apribowo, C., Ibrahim, M., & Wicaksono, F. (2018). Optimal power flow with optimal placement of TCSC device on 500 kV Java-Bali electrical power system using genetic algorithm-Taguchi method. *AIP Conference Proceedings*.
- Araga, I., Anibasa, A., & Alabi, I. (2017). Placement of multiple SVC on Nigerian grid system for steady state operational enhancement. *American Journal of Engineering Research*, 6(1), 78.
- Besharat, H., & Tahar, S. A. (2008). Congestion management by determining optimal location of TCSC in deregulated power systems. *International Journal of Electrical Power and Energy Systems*, 30(10), 563-568.
- Chakravarthy, V. P., & Vaisakh, K. (2017). Optimal placement of shunt and series compensators for minimization of losses and maximization of TTC using PSO. *Imperial Journal of Interdisciplinary Research*, 3(3).
- Devabalaji, K., & Ravi, K. (2015). Optimal size and siting of multiple DG and DSTATCOM in radial distribution system using bacterial foraging optimization algorithm. *Ain Shams Engineering Journal*, 1-13.
- Duraisamy, P., & Ponnusamy, A. (2017). Power system performance improvement by optimal placement and sizing of SVC using genetic algorithm. *International Journal of Applied Power Engineering (IJAPE)*, 6(2), 56-63.
- Ebeed, M., Kamel, S., Aleem, S. H. A., & Abdelaziz, A. Y. (2018). Optimal allocation of compensators for electric

- distribution network planning. Springer, 321-353.
- Farsangi, S. E., Rashedi, E., & Farsanji, M. M. (2017). Multi-objective VAR planning using fuzzy-GSA. *Swarm Intelligence and Evolutionary Computation (CSIEC) 2017 2nd Conference*, IEEE.
- Guo, D., & Xian, Y. (2013). Optimal allocation of superconducting fault current limiter using multi-objective estimation of distribution algorithm based on bacterial foraging. *IEEE International Conference on Applied Superconductivity and Electromagnetic Devices*, Beijing.
- Jumaat, S., Musirin, I., Othman, M., & Mokhlis, H. (2012). Placement and sizing of thyristor controlled series compensator using PSO based technique for loss minimization. *IEEE International Power Engineering and Optimization Conference*, Melaka, Malaysia.
- Melodi, A., & Akinloye, B. (2014). Transmission capacity enhancement for Nigeria power transmission grid using TCSC and UPFC. *Journal of Engineering and Engineering Technology*, 8(2), 82-90.
- Mubeen, S., & Dhananjay, Y. (2022). A review of particle swarm optimization (PSO) algorithm. *International Journal of Mechanical Engineering and Technology (IJMET)*, 19-44.
- Obiora. (2019). Power devolution and electricity transmission in Nigeria: A study in resources mobilization for economic development. *Advances in Social Sciences Research Journal*, 6(4), 340.
- Padiyar, R. (2007). *FACTS controllers in power transmission and distribution*. New Delhi: New Age International (P) Limited, Publishers.
- Passino, K. (2002). Biomimicry of bacterial foraging for distributed optimization and control. *IEEE Control System Magazine*, 52-67.
- Rehtanz, C., & Zhang, J. (2014). New types of FACTS devices for power system security and efficiency. 1-3.
- Sirjani, R., Mohamed, A., & Shareef, H. (2011). Optimal placement and sizing of static var compensators in power systems using improved harmony search algorithm. *Przeglad Elektrotechniczny*, 87(7), 214-218.
- Tomonobu, S., Salem, A., & Al-Attar, K. (2021). Nature-inspired algorithms applications to power system optimization. *Aswan University Journal of Science and Technology*, 1.
- Udgir, S., Srivastava, L., & Pandit, M. (2014). Optimal placement and sizing of SVC for loss minimization and voltage security improvement using differential evolution algorithm. *Recent Advances and Innovation in Engineering (ICRAIE)*, IEEE.
- Umar, M., Abdullahi, A., & Yuvaraj, T. (2019). Application of bacterial foraging algorithm in the allocation of DSTATCOM in 50-bus canteen feeder. *Journal of Electrical Engineering*, 18(1).
- Umar, M., Abdullahi, A., Shehu, M., & Abdullahi, M. (2018). Optimal allocation of SVCs in transmission networks considering system loadability using exponential adaptive bacterial foraging algorithm. *Department of Electrical and Computer Engineering, Ahmadu Bello University, Zaria, Nigeria*.
- Xing. (2014). *Innovative computational intelligence: A rough guide to 134 clever algorithms*. Springer, Berlin, Germany.
- Yang, H., Tang, W., & Lubicki, P. (2017). Placement of fault current limiters in a power system through a two-stage optimization approach. 1.

**Disclaimer/Publisher's Note:** The statements, opinions and data contained in all publications are solely those of the individual author(s) and contributor(s) and not of the publisher and/or the editor(s). This publisher and/or the editor(s) disclaim responsibility for any injury to people or property resulting from any ideas, methods, instructions or products referred to in the content.

© Copyright (2024): Author(s). The licensee is the journal publisher. This is an Open Access article distributed under the terms of the Creative Commons Attribution License (<http://creativecommons.org/licenses/by/4.0>), which permits unrestricted use, distribution, and reproduction in any medium, provided the original work is properly cited.

Peer-review history:  
The peer review history for this paper can be accessed here:  
<https://www.sdiarticle5.com/review-history/126167>