



A Comparative Analysis of SIMC-PID with Other Conventional Techniques for Automobile Vehicle Air Conditioning System Control

Isaiah Adebayo^{1*}, David Aborisade¹ and Ogunkeyede Yinka²

¹*Department of Electronic and Electrical Engineering, Ladoke Akintola University of Technology, P. M. B. 4000, Ogbomosh, Oyo State, Nigeria.*

²*Department of Electronic/ Electrical Engineering, Osun state College of Technology, Esa Oke, Nigeria.*

Authors' contributions

This work was carried out in collaboration between all authors. Author OY designed the study, performed the statistical analysis, wrote the protocol, and wrote the first draft of the manuscript. Authors DA and IA managed the analyses of the study. Authors DA and IA also managed the literature searches. All authors read and approved the final manuscript.

Article Information

DOI: 10.9734/JSRR/2020/v26i1130333

Editor(s):

(1) Professor. Cheng-Fu Yang, National University of Kaohsiung, Taiwan.

Reviewers:

(1) S. Meena, St. Joseph's College of Engineering, India.

(2) Jianping Wen, Xi'an University of Science and Technology, China.

Complete Peer review History: <http://www.sdiarticle4.com/review-history/64347>

Received 25 October 2020

Accepted 30 December 2020

Published 31 December 2020

Original Research Article

ABSTRACT

Decreasing the thermal increase inside vehicles and safeguarding suitable vehicular temperature levels may result in improved vehicle fuel economy, reliability and passenger comfort. However, getting suitable techniques to attain this has been a great challenge to the system engineers. Although, the use of conventional techniques have proffered a great insight in solving the problem of temperature control in air conditioning system, however, they suffered from inefficient and non-lasting solution to the heat generated within the cabin walls. Thus, in this present paper, a Simple Internal Model Control based Proportional Integral Derivative (SIMC-PID) controller for automobile vehicle temperature is proposed. The SIMC method is based on the internal model control (IMC) theory and proposes a simple methodology for the tuning of the PI and PID industrial controllers. The suggested approach is compared with the conventional tuning methods such as Zeigler-Nichols, Cohen-Coon and Chien-Hrones-Reswick based on energy conservation and mass

*Corresponding author: E-mail: igadebayo@lautech.edu.ng, isaiahadebayo@yahoo.com;

balance principles. Results obtained showed that the proposed SIMC-PID method could be of great significance in controlling the air-conditioning system temperature compared with the conventional tuning techniques.

Keywords: Auto-tuned PID Controller; automobile vehicle; Matlab-Simulink; temperature control performance.

1. INTRODUCTION

Operational heat management of vehicles entails new and improved systems and approaches aimed at decreasing the generation and displacement of heat within and around a vehicle. This can be achieved either directly or indirectly, and can have substantial effects on a host of essential [1].

Thermal surroundings in passenger cars differs from those in buildings and is frequently highly non-uniform and asymmetric [2]. This may be due to the air-conditioning that is typically not triggered when there is nobody in the car or when the engine is not running, causing occurrence of extreme microclimate conditions. There are several important factors influencing road accidents. Temperature inside the vehicle is ranked third after alcohol and seat belts. Besides, in moderate outdoor conditions, vehicle passenger section is subjected to numerous heat loads, such as direct and reflected solar radiation, heat transfer through the cab walls as a result of the temperature difference, heat released by the passengers (sensible and latent), and heat gain from the powertrain. This can result in the increase in the interior air and surfaces temperatures above the acceptable values, making the ambient uncomfortable, reducing the driving performance, possibly leading to the risk of hyperthermia. As a consequent, conserving thermal comfort in the passenger section is vital. Thermal comfort is provided by the air conditioning system, which takes in much energy [3]. A considerable number of authors have worked on diverse methods that may be used to control temperature of the vehicle air conditioning system [4]. For instance, [5] presents a review of factors which affect the heat comfort inside of vehicle. These factors can be categorized into two classes, namely, measurable factors, which comprise: the air temperature, air velocity, radiant temperature and relative humidity and personal factors which include: activity level and clothing insulation. Authors of [6] also presents a method for controlling the temperature and relative

humidity of air-conditioned rooms with IMC-PID controller for the multivariable system. An effort was made to solve the problem, using the example of an electrically powered vehicle [7]. In [8], the tests were performed on a group of fifty people that were indiscriminately selected to drive under three different climatic conditions: under cold, neutral and hot conditions, which related to 5°C, 20°C, and 35°C, respectively. In all the cases, the same relative humidity conditions of 50 % were kept. The best driver's performance was observed under neutral conditions. During the tests, which lasted 30 minutes, no effect of ambient temperature on the human body temperature and the heart rate was reported. However, the driving value was very much affected by the driver's concentration, which deteriorated significantly when the air conditioning parameters were controlled manually. Additionally, it was found that the manual selection of the direction of the air flow affected the thermal comfort of occupants and the efficiency of the HVAC system [9]. Therefore, this paper brings the possibility of adaptive an accurate mathematical Heating Ventilation Air Condition (HVAC) model for the necessity, subjectivity of thermal comfort and intelligent control systems are suggested for the strategies for achieving superior results in HVAC applications. Also, a method combining the simplicity, adaptability, and flexibility of Simple Internal Model Control with the mathematical precision of the Proportional Integral Derivative controller (SIMC-PID) for the automotive vehicle air conditioning system was proposed. The SIMC-PID controller is used for an automotive vehicle air conditioning system in order to give a satisfactory control performance under different operating conditions.

The remainders of this paper are organized as follows: Section 2 give a brief description of the intelligent controllers used in this paper. The mathematical formulations of the proposed SIMC-PID controller are presented in section 3 while results and discussion are presented in section 4. Section 5 concludes the work.

2. INTELLIGENT CONTROLLERS

2.1 PID Controller

PID control is a very straightforward system. The block diagram of a conventional PID controller is shown in Fig. 1. Basically, the signal driving the plant is made up of a proportional gain (K_p), an integral gain (K_i) and a derivative gain (K_d). PID controller has all the necessary dynamics: fast reaction on change of the controller input (D mode), increase in control signal to lead error towards zero (I mode) and suitable action inside control error area to eliminate oscillations (P mode). Derivative mode improves the stability of the system and enables an increase in gain K and a decrease in integral time constant T_i , which increases the speed of the controller response [10].

$$e(t) = T(t) - T_o \quad (1)$$

With $T(t)$ being the measured temperature input and to be the set point temperature. The control voltage $u_c(t)$ takes the form:

$$u_c(t) = K_p e(t) + K_i \int e(t) dt + K_d \frac{de(t)}{dt} \quad (2)$$

$$u(t) = K(e(t) + \frac{1}{T_1} \int_0^t e(\theta) + T D e(t)) \quad (3)$$

$$K(s) = K(1 + \frac{1}{T_1 s} + T_D s) \quad (4)$$

The variable $e(t)$ represents the tracking error which is the difference between the desired input value and the actual output.

$$U(t) = K_p e(t) + K_i \int_0^t e(t) dt + K_d \frac{de(t)}{dt} \quad (5)$$

Error $e(t)$ is the difference between the setpoint and plant output.

2.2 Ziegler-Nichols Method

The closed-loop simulation in tuning PID was proposed by Ziegler and Nichols in 1942 also known as "Ultimate Cycle Method" used in determining the parameter values of each controller such as the Proportional gain (K_p), Integral gain (K_i) and Derivative gain (K_d). The process reaction curve is shown in Fig. 2. Ziegler-Nichols method has been employed to overcome the overshoot problem of reference speed with the actual speed under no-load and eliminates the steady-state error [12]. In industrial process control systems, a large variety of plants can be approximately modeled by First Order plus Dead Time (FOPDT) [13].

$$G(s) = \frac{K}{Ts+1} e^{-sL} \quad (6)$$

Where

- k = System gain
- L = Time delay in system response
- T = Time constant

2.3 Cohen-Coon Method

The Cohen-Coon method is an open loop method for tuning PID that employs the system's response to manual step changes without the controller operating initial values for the PID parameters and then tune them manually. Cohen-Coon method is a modified version of Ziegler Nichols PID tuning method which provides a good approximation to process reaction curve by First Order plus Dead Time Model (FOPDT) and the method of tuning PID gains to achieve good response more sensitive than the Ziegler-Nichols method [15]. Based on the FOPDT model, controller parameters with this method is denoted as $a = \frac{KL}{T}$ and $t = \frac{L}{(L+T)}$

The Cohen-Coon method is classified as 'offline' method for tuning, meaning that a step can be introduced to the input once it is at steady state, the output can be measured based on the time constant, the time delay and the responses can be used to evaluate the initial control parameters [16]. The tuning controller eliminates the steady-state response given by the Ziegler-Nichols method when there is a large dead time 't' (process delay) relative to the open-loop time constant; a large process delay is necessary to make this method practical because unreasonably large controller gains will be predicted.

2.4 Chien-Hrones-Reswick Method

Chien-Hrones-Reswick (C-H-R) method is another open-loop modification of Ziegler Nichols for tuning the PID controller [17]. This method was developed in 1952 by C-H-R provides a better way to select a compensator for process control applications, also C-H-R method uses the time constant T of the plant explicitly and proposed to use "quickest response without overshoot" or "quickest response with 20% overshoot" as a design criterion [13]. To tune the controller according to the C-H-R method the parameters of first-order plus dead time model are determined in the same manner of the Ziegler-Nichols method, The tuning rules based on the 20% overshoot design criterion are quite

similar to the Ziegler Nichols method. However, when the 0% overshoot criteria are used, the proportional gain and the derivative time are smaller while the integral time is larger. The C-H-R for Proportional (P), Proportional Integral (PI), and Proportional Integral Derivatives (PID) controller tuning formulas are summarized in terms of set-point regulation and disturbance rejection [17].

2.5 IMC Controller

The Internal Model Control (IMC) philosophy relies on the Internal Model Principle, which states that control can be achieved only if the control system encapsulates, either implicitly or

explicitly, some representation of the process to be controlled [17]. The schematic diagram of the IMC controller is shown in Fig. 3.

A controller, $G_c(S)$, is used to control the process, $G_p(S)$. By setting $G_c(S)$ to be the inverse of the model of the process.

Thus, the IMC has the following properties:

- It provides time-delay compensation.
- The filter can be used to shape both the set point tracking and disturbance rejection responses.
- At the steady-state, the controller will give offset free responses.

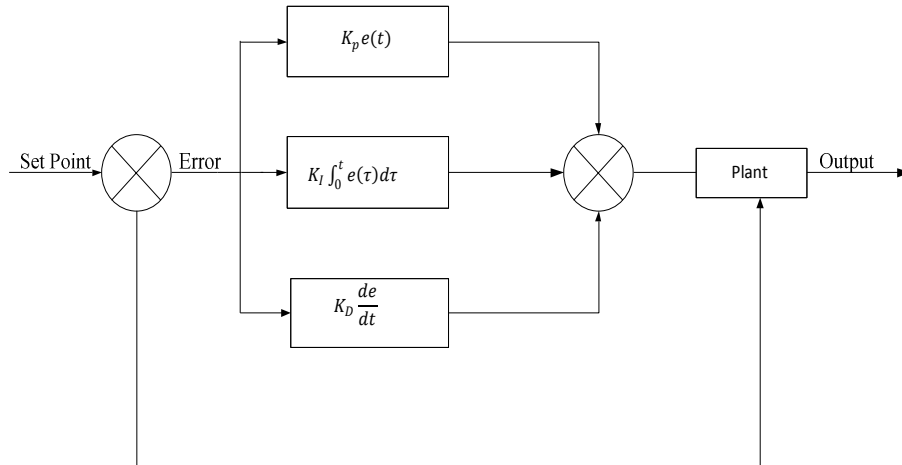

Fig. 1. Basic block diagram of a conventional PID controller [11]

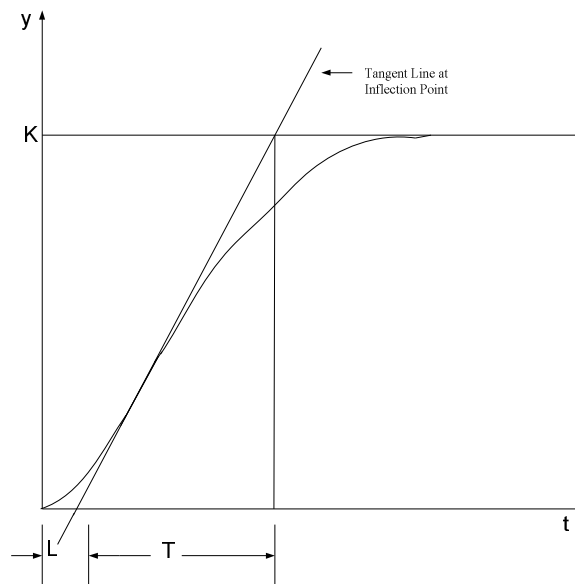

Fig. 2. Process Reaction Curve [14]

Since the sensitivity function determines performance whilst the complementary sensitivity function determines robustness, this implies that (compared to the conventional control scheme) the IMC provides a much easier framework for the design of robust control systems.

3. PROPOSED SIMC PID CONTROLLER

The SIMC tuning technique is based on the internal model control (IMC) theory and proposes a simple methodology for the tuning of the PI and PID industrial controllers. This design methodology is used especially for the control of systems of first and second-order with delay. The principal advantage of this design technique is the simplicity in the determination of the parameters of the PID controllers for first and second-order systems and the robustness of the control system facing changes in the set point, presence of external disturbances and random noise [18], the structure of the SIMC PID controller is given by the interacting form of the PID controller.

$$G_c(s) = k' \left(1 + \frac{1}{Ti(s)} \right) (1 + T'ds) \quad (7)$$

Fig. 4 shows the block diagram of the skogestad for the internal model control based proportional integral derivative controller. Skogestad based internal model control method is one of the best and easy methods used in controlling processes with time delay and inverse response. It is fast in the speed of response, good disturbance

rejection Stability, robustness with small input usage [19]. From the block diagram of Fig. 4, SIMC-PID represents the controller used, SIMC is used to tune the parameters of the PID to give a desired temperature at a faster robust time. HVAC, is the parameter worked on to reduce the heating capacity of the vehicle. Thermal space is the environment within the Air conditioning system and the vehicle, the human, ventilation and the environment. Thermistor, is to measure the temperature range of degree of hotness or coldness of the environment of the air condition and the occupants.

The SIMC rules are to be derived using the method of direct synthesis for set points. However, it is noticed that the SIMC rules only apply to processes that can be reasonably well approximated by first or second-order plus delay models. This applies to most process control applications.

$$k_c = \frac{1}{k'} \cdot \frac{1}{(\theta + \tau_c)} \quad (8)$$

$$\tau_1 = \min(\tau_1, 4(\tau_c + \theta)) \quad (9)$$

Where

T, the temperature range set to reach the desired output.

k, is the plant gain, Ki is the derivation in the first order derivative of the plant gain.

τ1 is the dominant lag time constant,

Θ is the (Effective) time delay (dead time),

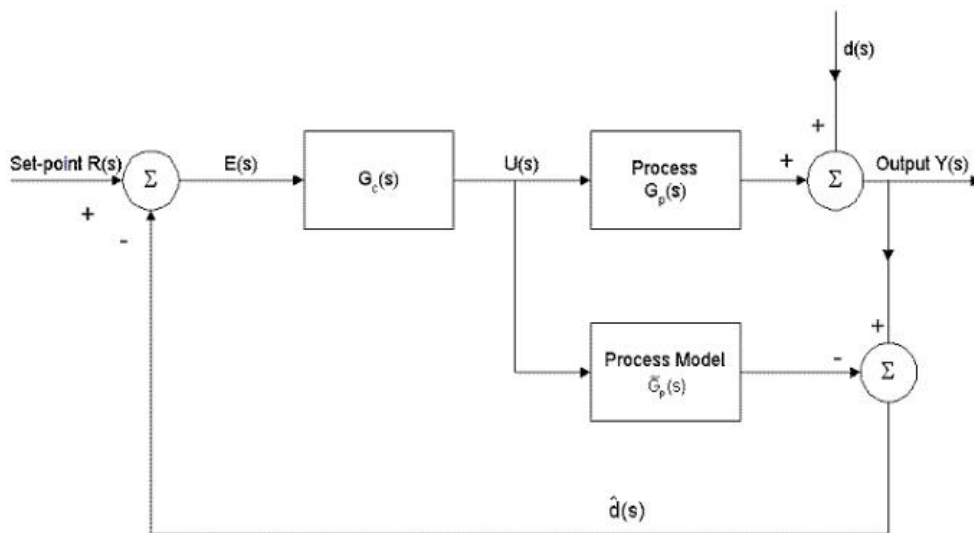

Fig. 3. Schematic diagram of the internal model control

Optional: Second-order lag time constant, τ_2 (for dominant second-order process for which $\tau_2 > q$, approximately).

The PID controllers are tuned using the SIMC method [20]. The control objectives are measured using open-loop controllability metrics and dynamical performance indices for closed-loop operation. The SIMC method was chosen due to its advantages regarding other model-based techniques [21].

3.1 Experimental Procedure

The performance of the simulated control model was based on rising time, overshoot time and settling time. The processes were repeated until the specifications are met. These parameters variation would determine system performance. Hence, the control system designs would benefit the system by viewing the resulting technique in both time and frequency-domain viewpoints. The flow chart of the developed SIMC-PID model is shown in Fig. 5. The simulation model is presented in Fig. 5(a-e) using MATLAB/Simulink package Version 2015b.

The process of developing an overall system model is concerned with the implementation of an appropriate method to automatically vary different system configurations. However, the efficient model analysis can only be achieved through accurate simulation of the developed model. The simulation process deals with performing experiments on the model to predict its behavior under the real conditions.

The mathematical modeling of the automotive vehicle air conditioning system is controlled by the SIMC-PID controller. The flow chart of the developed SIMC-PID model and the simulation model was done using MATLAB/Simulink package Version 2017b. The following Simulink were built for the model for the developed of the results and the comparison of results of the control techniques.

4. RESULTS AND DISCUSSION

The results obtained showed the effectiveness and better performance of automotive vehicle temperature 40°C in terms of rise time, settling time and percentage overshoot using SIMC-PID controller and with other tuning controllers Cohen-Coon-PID, Chien-Hrones-Reswick-PID and Ziegler-Nichols-PID. The Fig. 6 shows the performance of the temperature control of the automobile vehicle using Cohen-Coon. The rise time is 0.90sec and the time required for the steady-state responses to settle within the certain overshoot percentage of 33.3% to its final value was 30sec at a temperature of 40°C. Fig. 7 shows the performance of the temperature control of the automobile vehicle using Chien-reswick. The rise time was 0.60sec via the time taken for the system responses to reach the steady-state value was 28sec within a certain percentage overshoot of 20.5% at a temperature of 40°C. Fig. 8 indicates the performance of the temperature control of the automobile vehicle using Ziegler Nichols. The rise time was 0.30sec and at a temperature of 40°C, the time required

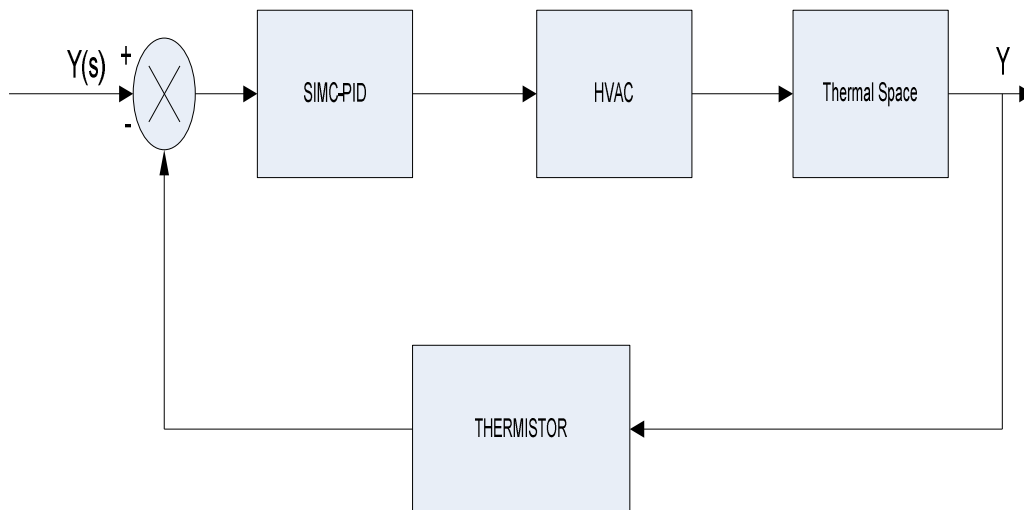

Fig. 4. Block diagram of the skogestad based internal model control based proportional integral derivative controller

for the steady-state responses to settle within the certain overshoot percentage of 13.3% to its final value was 25sec. Fig. 8 indicates the performance of the temperature control of the automobile vehicle using SIMC-PID. The rise

time was 0.10sec and at a temperature of 40°C, the time required for the steady-state responses to settle within the certain overshoot percentage of 10.2% to its final value was 21sec.

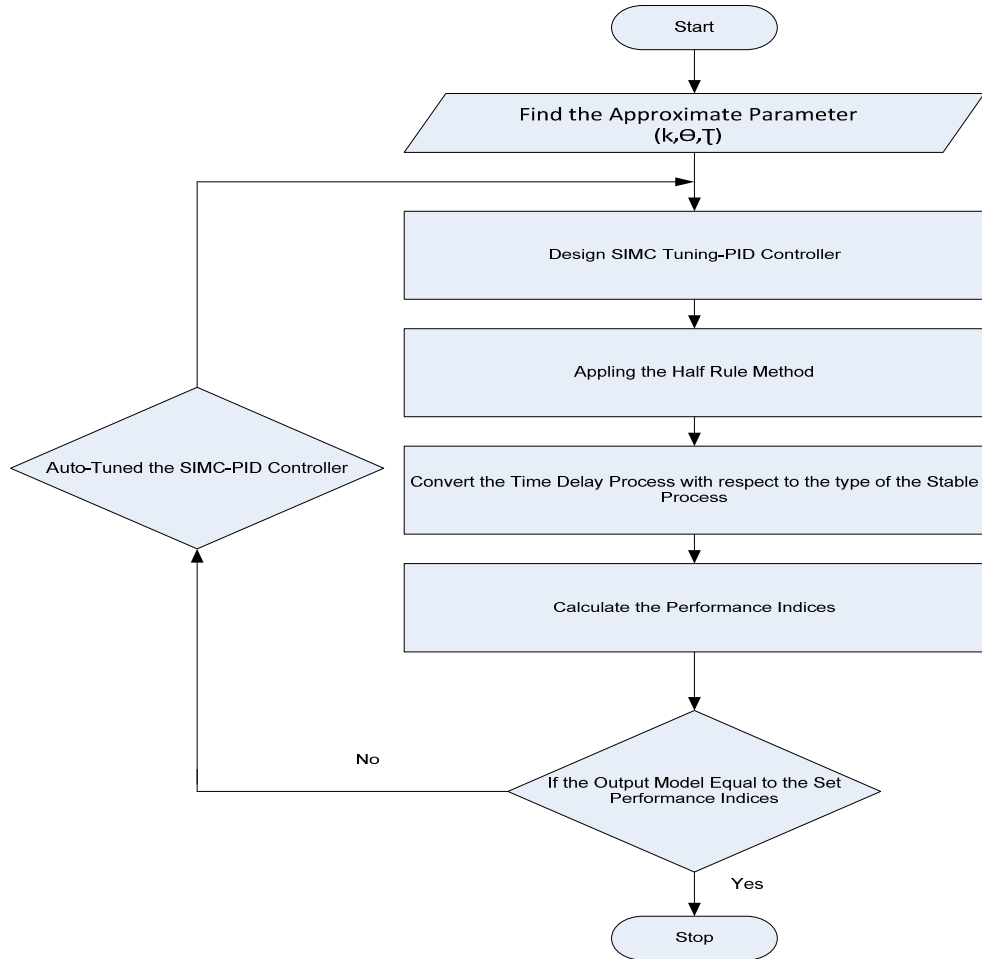

Fig. 5. Flowchart of the proposed system

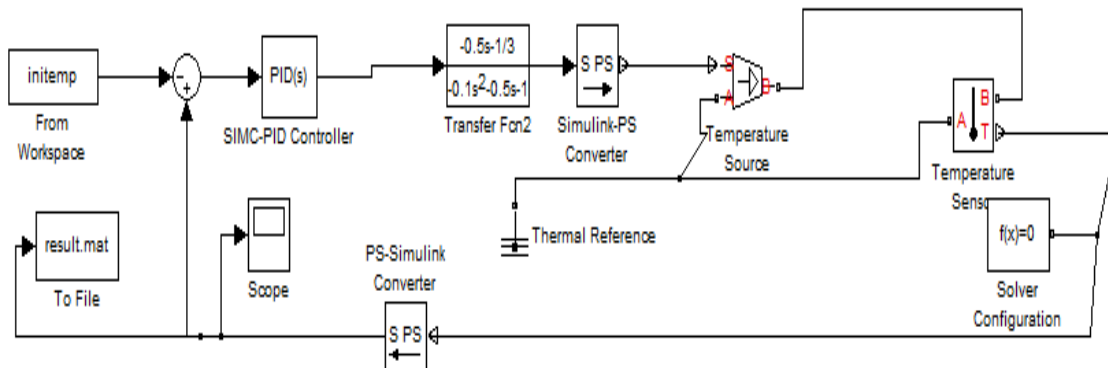

Fig. 5a. Block diagram of a controlled SIMC-PID

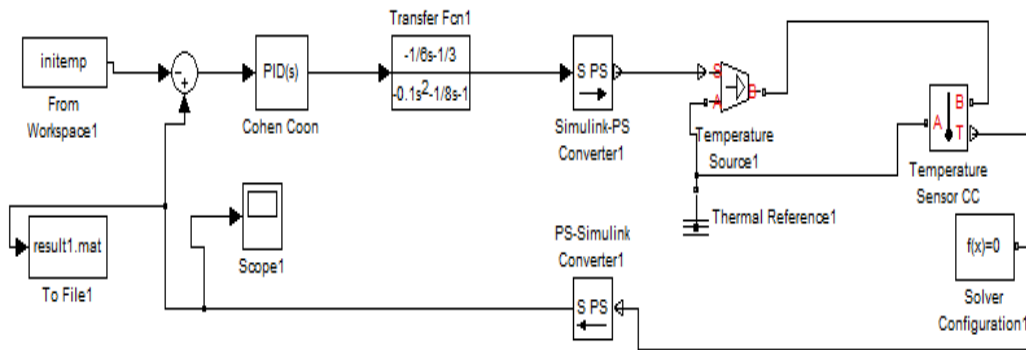

Fig. 5b. Block diagram of the simulation model of Cohen coon

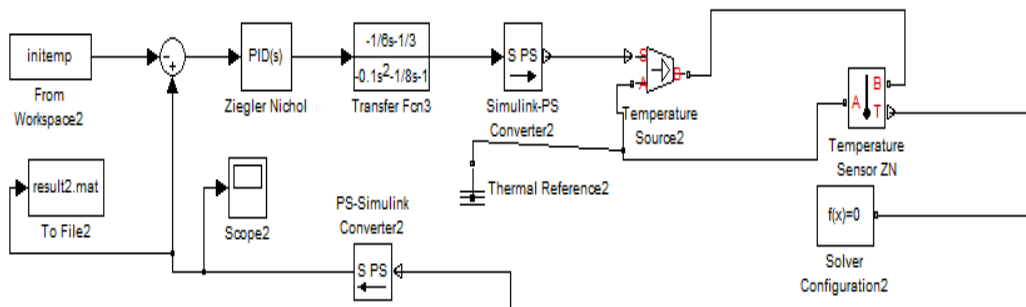

Fig. 5c. Block diagram of the simulation model of Ziegler Nichol

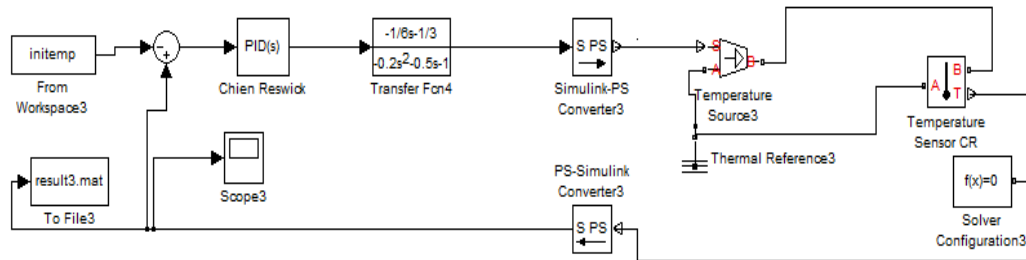

Fig. 5d. Block diagram of the simulation model of Chien keswick

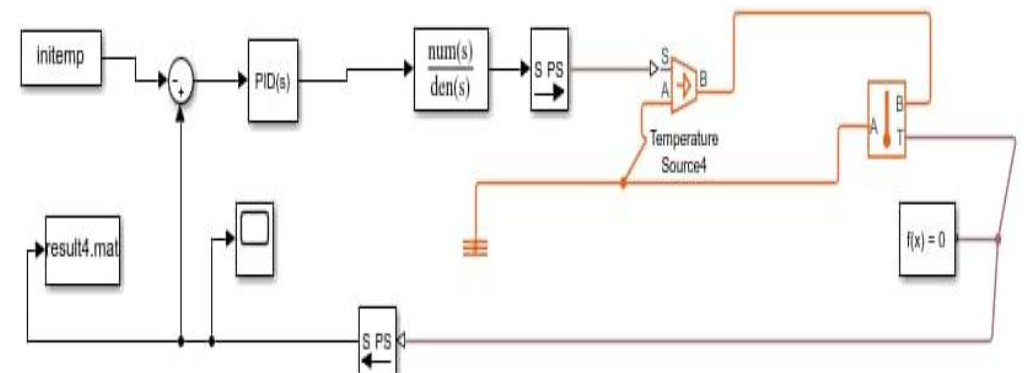

Fig. 5e. Block diagram of the simulation model of the PID Controller

Fig. 8 showed the comparison performances of Ziegler-Nichols-PID and SIMC-PID controller for Cohen-Coon-PID, Chien-Hrones-Reswick-PID, automobile vehicle temperature control. The

desired temperature was set to 40°C which falls within the thermal zone respect with the vehicle humidity in terms of rise time, settling time and overshoot percentage as shown in Table 1. This reflects the superior performance of the SIMC PID over other investigated controllers.

Ziegler-Nichols-PID and SIMC-PID controller for automobile vehicle temperature control. The desired temperature was set to 30°C which falls within the thermal zone respect with the vehicle humidity in terms of rise time, settling time and overshoot percentage as shown in Table 2. This reflects the superior performance of the SIMC PID over other investigated controllers.

Fig. 9 showed the comparison performances of Cohen-Coon-PID, Chien-Hrones-Reswick-PID,

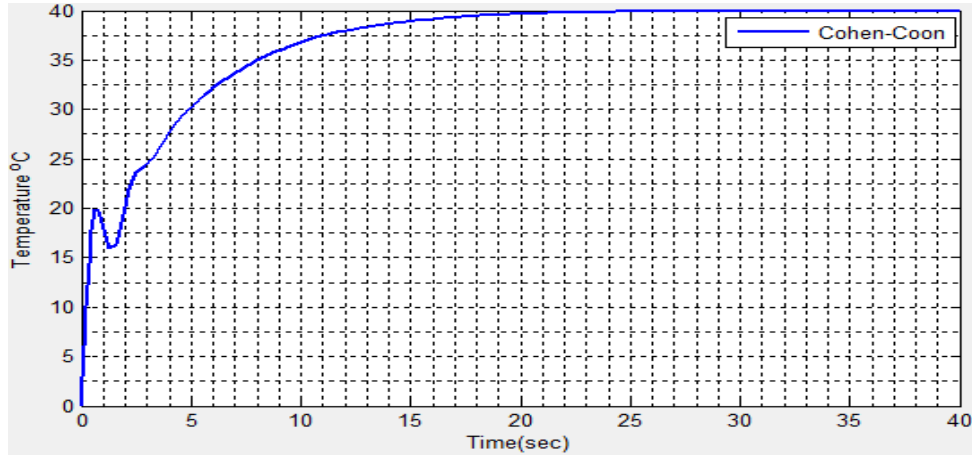

Fig. 6. Automobile vehicle temperature control using Cohen-Coon of 40°C

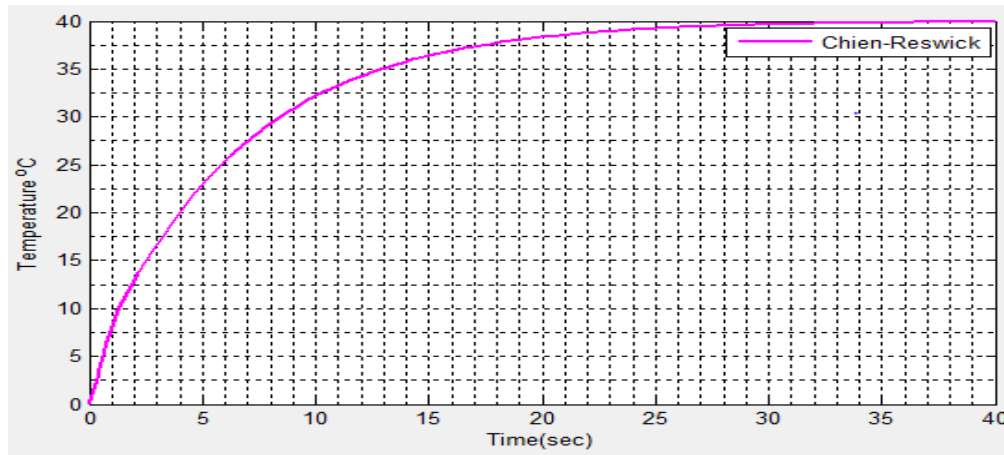

Fig. 7. Automobile vehicle temperature control using Chien-Reswick of 40°C

Table 1. Cohen-Coon, Chien-Reswick, Ziegler Nichols and SIMC-PID for automobile vehicle temperature control of 0°C to 40°C

Controllers	Rise time (Sec)	Settling time (Sec)	Overshoot (%)
Cohen-Coon-PID	0.90	30.0	33.3
Chien-Hrones-Reswick-PID	0.60	28.0	20.5
Ziegler-Nichols-PID	0.30	25.0	13.3
SIMC-PID	0.10	21.0	10.2

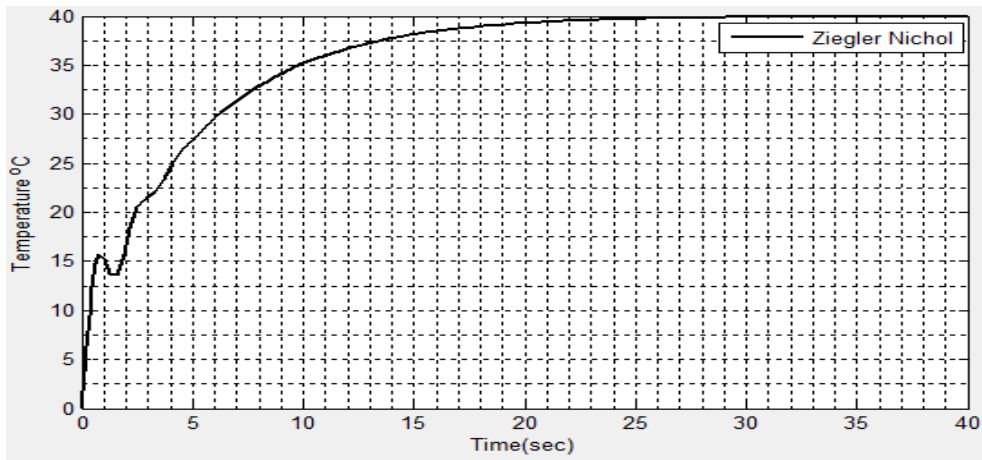

Fig. 8. Automobile vehicle temperature control using Ziegler-Nichols of 40°C

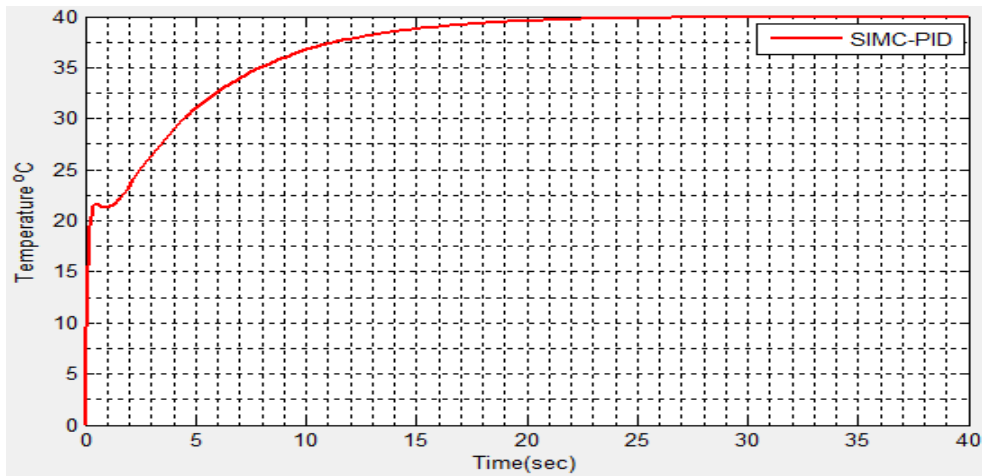

Fig. 9. Automobile vehicle temperature control using SIMC-PID of 40°C

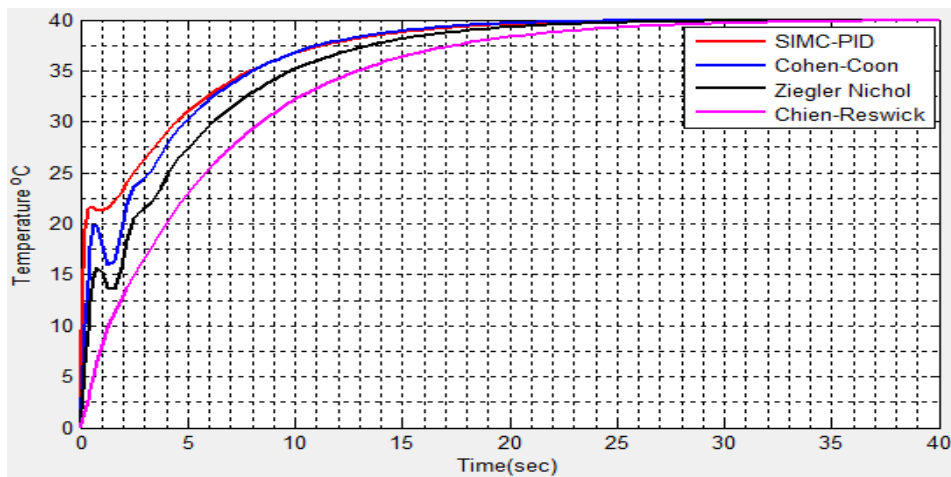

Fig. 10. The Comparison of Cohen-Coon, Chien-Reswick, Ziegler Nichols and SIMC-PID for Automobile Vehicle Temperature Control of 0°C to 40°C

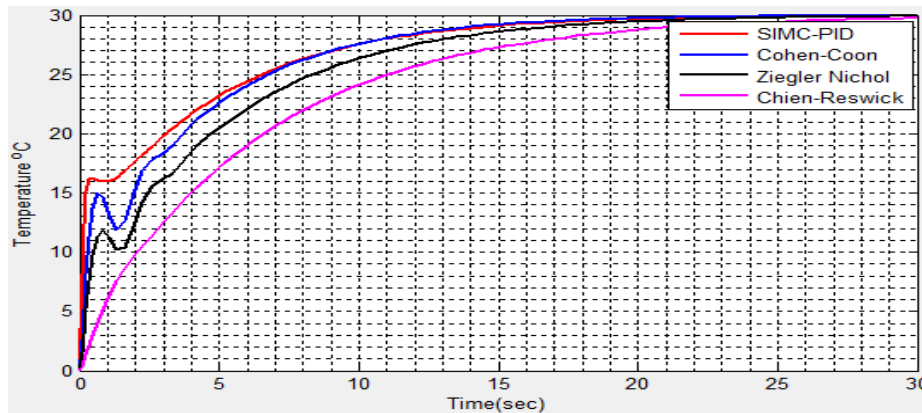

Fig. 11. The comparison of Cohen-Coon, Chien-Reswick, Ziegler Nichols and SIMC-PID for automobile vehicle temperature control of 0°C to 30°C

Table 2. Cohen-coon, Chien-Reswick, ziegler nichols and SIMC-PID for automobile vehicle temperature control of 0°C to 30°C

Controllers	Rise time (Sec)	Settling time (Sec)	Overshoot (%)
Cohen-Coon-PID	0.60	28.0	24.5
Chien-Hrones-Reswick-PID	0.40	27.0	19.5
Ziegler-Nichols-PID	0.20	24.0	13.1
SIMC-PID	0.10	19.0	10.1

5. CONCLUSION

The performance of Cohen-Coon-PID, Chien-Hrones-Reswick-PID, Ziegler-Nichols-PID and SIMC-PID for temperature control of automobile vehicle used by heating ventilation and air conditioning engineers to design more efficient air conditioning systems for different applications such as the cabin temperature control technique that aids better driving performance based on a good rise time, percentages overshoot and settling time on the cabin temperature so as to reduce the heating loss of energy and fuel consumption were investigated in this paper. The results of the simulation showed that SIMC-PID controller demonstrated a superior performance over other controllers investigated based on the performance metrics used.

CONSENT

It is not applicable.

ETHICAL APPROVAL

It is not applicable.

COMPETING INTERESTS

Authors have declared that no competing interests exist.

REFERENCES

- Garrett J. Marshall, Colin P. Mahony, Matthew J. Rhodes, Steve R. Daniewicz Nicholas Tsolas, Scott M. Thompson thermal management of vehicle cabins, external surfaces, and onboard electronics: An Overview. *Engineering*. 2019;5:954–969. Available: <https://doi.org/10.1016/j.eng.2019.02.009>
- Dragan R. Improvement of thermal comfort in a passenger car by localized Air distribution. *Acta Technical Conviensis-Bulletin of Engineering*, Tome IV, 2011. ISSN 2067-3809
- Tadeusz O, Zbigniew S. Evaluation of thermal conditions inside a vehicle cabin. *EPJ Web of Conferences*. 2016;114:02085.
- Arens E, Zhang H, Huizenga C. Partial- and whole-body thermal sensation and comfort. Part I and II, *Journal of Thermal Biology*. 2006;31:53–66.
- Anderson M, Young P, Hittle , Anderson C, Hodgson D. MIMO robust control for heating, ventilating and air conditioning (HVAC) systems. *Proceeding of the 41st IEEE Conference on Decision and*

- Control, Las Vegas, Nevada, USA. 2002; 167-172.
6. Xiaochen ZENG, Chunxuan YU. Multivariable IMC-PID within air-conditioned room temperature and relative humidity control system. IEEE Proceedings of the 33rd Chinese Control Conference Nanjing, China. 2014;28-30.
 7. Amanda Danielle O, da S, Dantas André Felipe O, De A. Dantas, João Tiago L, Campos S, Domingos L, De Almeida Neto, Carlos Eduardo T. Dórea PID. Control for electric vehicles subject to control and speed signal constraints. Journal of Control Science and Engineering. 2018;1-11. Article ID 6259049. Available:<https://doi.org/10.1155/2018/6259049>.
 8. Daanen HAM, Vliert E, Huang XU. Driving performance in cold, warm, and thermoneutral environments. Appl Ergon. 34(6):597-602. DOI: 10.1016/S0003-6870(03)00055-3
 9. Fišer J, Jícha M. Prediction of car cabin environment by means of 1D and 3D cabin model. EPJ Web of Conferences, 2013;45.
 10. Phillips CL, Harbor RD. Feedback control systems, 2nd Ed., Prentice-Hall; 1991.
 11. Sangram K, Mehetab A. "Design and tuning method of pid controller based on fuzzy logic and genetic algorithm". 20011;3(5)65.
 12. Dayar Mehdi. Ghosen Amin, Kumar Mohsen. The speed control traction motor using different optimization techniques based pid controller Journal of Basic Scientific Research, ISBN: 6488-6494. 2012;2(7)548.
 13. Satya S, Omhari G. New techniques of PID controller tuning of a dc motor-development of a toolbox. MIT International Journal of Electrical and Instrumentation Engineering. 2012;2(2):65-69.
 14. Ogata K. "Modern control engineering", 2nd Edition Prentice Hall. 1990;1(6)102.
 15. Dingyu X. "Analysis and design of linear feedback control" The Society for Industrial and Applied Mathematics. 2007;200-210.
 16. Hossein M, Seyed HS, Maryam G, Hamid T. Control techniques in heating, ventilating and air conditioning (HVAC) systems, KN Toosi University of Technology, Tehran, Iran; 2008.
 17. Ming T. Tham lecture notes on Introduction to Robust Control; 2002. Available:<http://ece662.cankaya.edu.tr>
 18. Vilanova R, Visioli A. PID control in the third millennium: Springer london dordrecht heidelberg new york; 2012. DOI 10.1007/978-1-4471-2425-2
 19. Skogestad S. Probably the best simple PID tuning rules in the world, Journal of Process Control. 2001;1-28.
 20. Skogestad S. Simple analytic rules for model reduction and PID controller tuning, Journal of process control. 2003;13:291-309.
 21. Skogestad S, Chriss G. The simc method for smooth pid controller tuning, PID control in the third millennium. Springer; 2012.

© 2020 Adebayo et al.; This is an Open Access article distributed under the terms of the Creative Commons Attribution License (<http://creativecommons.org/licenses/by/4.0>), which permits unrestricted use, distribution, and reproduction in any medium, provided the original work is properly cited.

Peer-review history:

The peer review history for this paper can be accessed here:
<http://www.sdiarticle4.com/review-history/64347>