

American Journal of Experimental Agriculture
2(3): 458-469, 2012

SCIENCEDOMAIN *international*
www.sciencedomain.org



Development of Cassava Digger and Conveyor Units

Danuwat Thangdee^{1*} and Seree Wongpichet¹

¹Department of Agricultural Engineering, Faculty of Engineering, Khon Kaen University, Khon Kaen 40002, Thailand.

Authors' contributions

All authors equally contributed to this work. All authors read and approved the final manuscript.

Research Article

Received 29th March 2012
Accepted 22nd May 2012
Online Ready 27th May 2012

ABSTRACT

Aims: To design and develop the cassava digging and preparing unit and the conveying unit for the Cassava Harvester Machine.

Study Design: Efficiency data.

Place and Duration of Study: Department of Agricultural Engineering, Faculty of Engineering Khon Kaen University, between September 2011 and February 2012.

Methodology: The Cassava Digging and Preparing Unit, and the Cassava Conveyor Unit were constructed. The Cassava Digging and Preparing Unit were functional tested on three digging angles of 20, 25 and 30 degrees on the three randomized soil moisture. The Cassava Conveying Unit was functional tested on six scooping speeds of 0.5, 1.0, 1.5, 2.0, 2.5 and 3.0 m/s. After adapted the two units to the results from above. The field performance test of the prototype machine was evaluated.

Results: The Digging and Preparing Unit found to be working on the angle of 20 degrees. The Conveyor Unit found to be scooping with less than 1.5 m/s of speed. The field performance test were showed that: filed capacity, field efficiency, and conveying losses were, 0.05 ha/hr., 59.10%, and 3.23% respectively without any losses caused by digging and preparing process.

Conclusion: From the functional test of Cassava Digging and Preparing Unit and Conveyor Unit that were designed and developed in this research, it has been found to have the ability to solve the problem in collecting and conveying cassavas from the ground.

*Corresponding author: Email: wtharngdee@yahoo.com, wtharngdee@gmail.com;

This data will pave the way for a prototype of Cassava Harvesting Machine to be fabricated.

Keywords: Digger; conveyor units; cassava harvesting machine; cassava.

1. INTRODUCTION

Thailand is one of the five countries that produces the most cassava and has been the number one exporter of cassava throughout the past ten years (FAO, 2011). For the country itself, cassava is an important crop. The process of cassava production requires much labor especially at harvest.

Currently the production of cassava as well as other crops in Thailand is facing a shortage of agricultural labor which also includes a shortage of agricultural machinery for replacing labor. One of the causes of the shortage of agricultural labor is the behavior of workers in the household. The farmers do not work in the agricultural sector currently. A survey by The National Statistical Office of the Agricultural Census in 2003 showed that the number of laborers in agriculture is declining steadily. Due to the expansion policy of compulsory education, the workers receive higher educational gains and do not return to work in the agricultural sector (Siamwala, 2004).

In the process of cassava production, the step of harvesting is the most severe problem. This process has developed using cassava rhizome excavation implement by both the government and the private sectors to replace the workers in cassava excavation. While the remaining steps, collecting the rhizome after digging, cutting them, and loading them onto trucks, are still done by the labor as before. The use of diggers is not yet very widespread. One reason is due to the existing digger which has replaced the laborers in cassava excavation only, but remains a process of manual labor like the original (Sukra, 1996a, 1996b; Monkolthanatat and Chamsing, 2007). Therefore, the development of the cassava digger to increase the ability to dig up the cassava rhizomes and pile them up at the same time will add the effectiveness in harvesting the cassavas for the current workforce which is limited.

From the information found, there has been research in the development of cassava digger and conveyor units by Odigboh and Ahmed (1982). They did research and developed a cassava digger, then collected the cassava rhizomes in a tray at the back of the digger, dropped them down and piled them up at the same distance of 10-15 meters along the length of every row. However, it has not yet been found that this prototype is being used by agriculturalists.

Later in 2002, Odigboh and Moreira (2002a) further developed the cassava digger and the conveyor units by using a bucket that is directly attached to the back of the digger. The cassava rhizomes are then transported to a trailer at the back in order to increase the distance of the bulk. There is no need to pile them up so closely, but several problems have been found: 1) The movement caused by the cassava rhizomes being taken from the soil surface always causes the bucket and the cassava rhizomes to be knocked the ground. This makes it hard to get the cassava rhizomes. 2) The weight of the bucket together with the

weight of the cassava rhizomes and the weight of the soil causes the chain to become twisted or broken. 3). The chain vent is always blocked with the soil and causes the chain not to be driven continuously. Because of these obstacles, this method has had to be abandoned. Later Odigboh and Moreira (2002b) have proposed to use the equipment to push the cassava rhizomes into the bucket so that the bucket will not touch the soil while gaining access to the cassava by using the bar device to sweep the cassava rhizomes from the ground and then passing them up to the inclined plane. When the cassava rhizomes have moved to the end of the inclined plane, they will fall into the bucket that comes right in time. From examining the document, the results of the test using the cassava rhizome sweeping device have not yet been found. It is expected that such a concept is still under development.

Due to the problem of transporting cassava rhizomes after excavation with the bucket above, this research study is interested in solving this problem. It's hypothesized that excavated cassava rhizomes must be prepared for scooping by the bucket. This can be done by breaking the soil clods into smaller sizes after the excavation and placing the cassava rhizomes after the excavation on the ground surface. This condition will help the bucket to scoop the cassava rhizomes from the ground. The weight of the conveyance should be reduced. There should only be the weight of the bucket and the weight of cassava rhizome for each conveyance.

The hypothesis of study mentioned has led to a source of study and development of two sets of devices which are the cassava rhizome digging and preparing unit and the conveyor units to get the cassava rhizomes from the ground and convey them to the collecting trailer.

2. MATERIALS AND METHODS

To achieve the above objective, the test kits for digging, preparing and conveying cassava rhizomes are made as shown in Fig. 1.

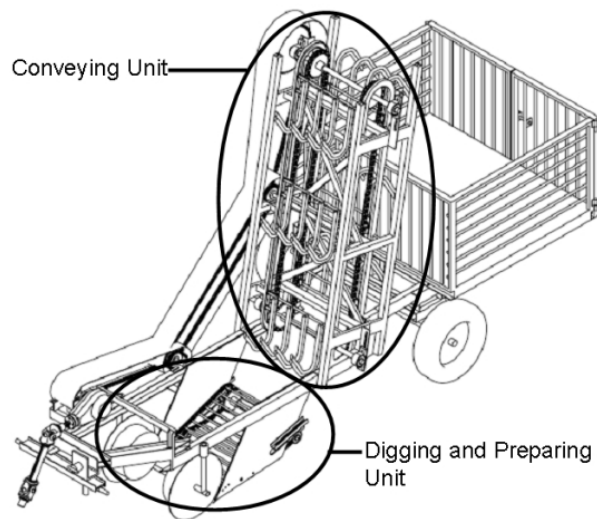

Fig. 1. The test kits for digging preparing and conveying cassava rhizomes

Test beds are prepared for cassava planting by using the method of agriculturalist. Plant 'Kasetsart 50' variety in a bed prepared with the average distance between the rows being 1.0 meter and the distance between the plants being 0.85 meters. The test bed is separated into 5 small plots each with the size of 3x80 meters. This bed is used for testing once a month during the harvest season (October –February). There are five tests altogether. In each test soil moisture will be reduced according to the nature of the area. The study is divided into two steps:

2.1 Function Test of Cassava Digging and Preparing Unit

The Digging and Preparing Unit is used to dig up cassava rhizomes from the ground, break the soil clods into smaller sizes after digging and then to put the cassava rhizomes on the broken soil clods to wait for the Conveying Unit attached to the back of the Digging Unit to scoop and convey the cassava rhizomes to the collecting trailer.

The Digging Unit used in study (Fig. 2) is designed to break the soil clods while digging the cassava rhizomes from the ground. The sifter at the end of Digging Unit will separate the cassava rhizomes from the soil after digging and make it possible to put them on the ground after the excavation.

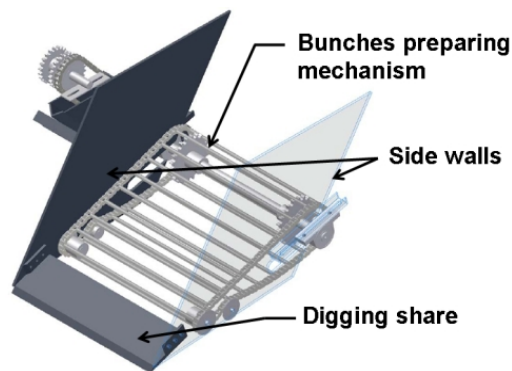

Fig. 2. Feature of the test kit for cassava digging and preparing unit

Factors used in testing consist of soil moisture at 5 levels (soil moisture in October, November, December, January and February). The declined angle test of the digger is at 3 levels: 20, 25 and 30 degrees.

Factors that control the stability during the testing period consist of a digger width of 700mm, a digger length of 200 mm and a speed of 0.69m/s. (2.5 km./hr.) without being connected to the conveying unit.

Result testing mean consists of percentage of soil clods bigger than 75 mm, the average size of soil clod, and the draft force measured by the method of RNAM Test Code and Procedure for Farm Machinery (RNAM, 1995). The details of the testing are as follows:

2.1.1 Test in soil that has moisture at Level 1 and randomly test in October. Prepare the bed by cutting down cassava plant 200-300 mm. above the ground.

2.1.2 Adjust digger to declined angle of 20 degrees.

2.1.3 Do the test draft force while the Digging and Preparing Unit which is mounted on the first tractor is not functioning. The gear of the tractor must be in neutral. Then use the second tractor to pull the first one past the draft force indicator. Read the draft force every 2m and then note the results.

2.1.4 Test the function of Digging and Preparing Unit. Install Digging and Preparing Unit on the first tractor. Use neutral gear for the first tractor. Put the digging unit on the tractor and let it function. Then use the second tractor to pull the first one past the draft force indicator. Read draft force mean every two meters throughout the test. Repeat the same process every 25 meters for three times and note the draft force mean.

2.1.5 Repeat the test in No. 2.1.4 by adjusting the digging angle of the digger to 25 and 30 degrees, respectively.

2.1.6 After the excavation test is complete, do the random test for the percentage of soil clods that are bigger than 75mm. and determine the average size of the soil clod. Due to the functioning of the Cassava Digging and Preparing Unit in 2.1.4 and 2.1.5, arrange the screen sizes 75, 50, 38 25,19,13,10, 6 and pan from the top to the bottom (RNAM, 1995). After that, the sampling area was randomly chosen. The soil in this area was dug, and then sieved with the screens. The weight of soil that retained on each screen was determined. Moreover, the soil clod that retained on the biggest screen was calculated by using equation (1) and (2).

$$\begin{aligned} &\text{Percentage of soil clod} \\ &\text{bigger than 75 mm} = \frac{\text{weight of soil clod retained on 75 mm sieve}}{\text{weight of soil sample}} \times 100 \end{aligned} \quad (1)$$

$$\text{DSC (mm)} = \frac{1}{W} (3A + 8B + 11.5C + 16D + 2E + 31.5F + 44G + 62.5H + NI) \quad (2)$$

Where,

- DSC = mean of soil clods diameter (mm.)
- W = (A+B+C+D+E+F+G+H+I)
- A...I = weight of soil retained on each sieve (kg)
- N = mean of measured diameter of soil clods retained on the largest aperture sieve (mm.)

2.1.7 Testing in soil at the second level of moisture content, random test in November, testing in soil at the third level of moisture content, random test in December, testing in soil at the fourth level of moisture content, random test in January and testing in soil at the fifth level of moisture content and a random test in February. Practical tests are done using the same process as in 2.1.1 – 2.1.6.

2.1.8 Analyze the details about soil clods bigger than 75 mm, the average size of soil clods, and the draft force when the digging angle of Digging and Preparing and the soil shows moisture at different levels. The choice of digging angle is based on the least number of soil clods bigger than 75 mm.

2.2 Function Test of Cassava Rhizome Conveyor Unit

Cassava Rhizome Conveyor Unit is trailed at the back of the digger. Its function is to take the cassava rhizome after they have been excavated from the ground and convey them to the collecting trailer.

Conveyor Unit used in this study (Figs. 3 and 4) is a conveying bucket which is designed in sparse bucket form with a width of 700 mm. and a depth of 377 mm.

After the test of Digging Unit is completed for each level of moisture (each month), the ability test in conveying will be held when 3 levels of declined angle are used (20, 25 and 30 degrees). Each level will test the bucket speed at 6 levels: 0.5, 1.0, 1.5, 2.0, 2.5 and 3.0 m/s.

Factors that control stability during testing are the digging speed at 0.69 m/s. (2.5 km./hr.). The mean of testing is the percentage of cassava rhizomes that can be collected.

The details of testing are as follows:

2.2.1 Testing on the soil for the first level of moisture content. Perform random test in October right after Cassava Digging and Preparing Unit Test. Prepare bed by cutting down the cassava plant to about 200 – 300 mm. above the ground.

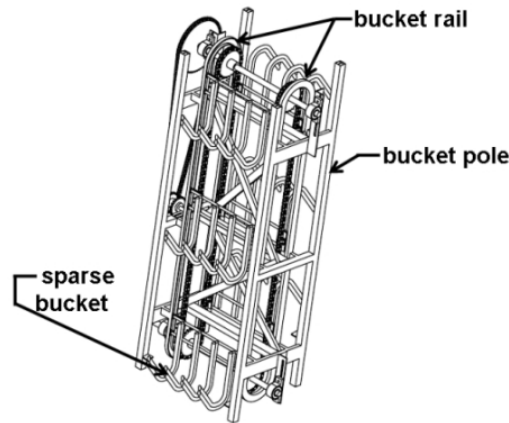

Fig. 3. Draft of conveyor unit

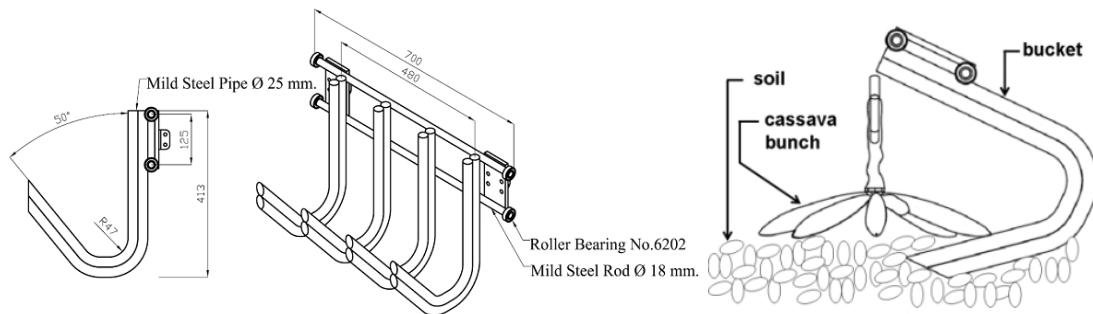

Fig. 4. Draft of designed bucket

2.2.2 Adjust digger to declined angle at 20 degrees. Adjust function speed of the bucket to 0.5 m/s. Dig cassava rhizomes and use Digger and Conveyor Units to gather them after that. The three replications of 25 m. plots will test. Note amount of cassavas that are collected.

2.2.3 Follow the test in 2.2.2 by adjusting function speed of the bucket to 1.0, 1.5, 2.0, 2.5 and 3.0 m/s, respectively.

2.2.4 Follow the test in 2.2.2 and 2.2.3 by adjusting angle of digger to 25 and 30 degrees.

2.2.5 Test on the soil with the second level of moisture content in November. Test on the soil with the third level of moisture content in December. Test on the soil with the fourth level of moisture content in January and test on the soil with the fifth level of moisture content in February. The practical test is the same as in 2.2.1 - 2.2.4

2.2.6 Analyze the percentage of ability in conveying cassava for Conveyor Unit by using equation 3. Choose the fastest speed of the bucket that can collect the most amounts of cassavas.

$$\text{Percentage of cassava collected} = \frac{\text{Amount of cassava scooped by bucket}}{\text{Total amount of cassava during the testing range}} \times 100 \quad (3)$$

2.3 Compatibility Test between Cassava Digger and Conveyor Units

After testing the functional factor of Cassava Digger and Preparing Unit and Conveyor Unit, the results of the test will be summarized and tested twice for the compatibility of the two devices in a bed 5 x 80 m. in size. The first time will be in January and the second time will be in February. Test methods are as follow:

2.3.1 Summarize information about factor test in October, November, December, and January. Adjust the function of both devices according to summary received. Test function ability of both devices in January once to study work capacity, work efficiency and the loss caused by these devices.

2.3.2 Summarize information about factor test in October, November, December, January, and February and adjust the function of both devices according to the summary received. Then test the function of the whole system in February. Use the same process as in 2.3.1.

2.3.3 The field capacity, field efficiency, and working losses then will be evaluate by the RNAM test code as the equation 4–6 respectively.

$$\text{Field Capacity} = \frac{A}{T_p + T_l} \text{ ha./hr.} \quad (4)$$

When

A = Area covered	ha.
T _p =Productive time	hr.
T _l = Non-productive time	hr.

$$\text{Field efficiency} = \frac{W_e \times T_p}{W_t (T_p + T_i)} \times 100 \quad (5)$$

When W_e = effective working width m.
 W_t = Theoretical working width m.

$$\text{Conveying losses} = \frac{\text{number of cassava retained on the ground}}{\text{all amount of cassava on the test range}} \times 100 \quad (6)$$

3. RESULTS AND DISCUSSION

The functional test for the Cassava Digging and Preparing Unit and Conveyor Units in the bed uses the agriculturalist’s method to plant and maintain the cassava. Testing in harvest season (Oct.-Feb.) shows the following results:

3.1 Functional Result of Cassava Digging and Preparing Unit

The result of the functional test of Cassava Digging and Preparing Units (Table 1) shows that there is still some rain in October. The average moisture content of soil is more than 25% (wb). The soil is soft but quite sticky. Therefore, the digger can’t separate cassava rhizomes from soil after digging.

Table 1. Result of functional test for cassava digging and preparing unit with different angles of digger in 5 levels of soil moisture

Month	Moisture (%wb)	Digging angle (Degree)	Size of soil clods after digging		The average of draft force (N)
			% of the soil clods bigger than 75 mm.	Average size of the soil clods (mm.)	
Oct	More than 25.0	-	Na	Na	Na
		20	46.5 ^a	69.0 ^a	4,149.5 ^a
Nov	12.0	25	44.8 ^a	99.3 ^b	4,488.1 ^b
		30	60.3 ^b	157.5 ^d	5,821.9 ^d
		20	41.6 ^a	87.1 ^a	4,786.3 ^c
Dec	6.0	25	50.0 ^{ab}	144.3 ^d	5,750.8 ^d
		30	61.0 ^{bc}	187.9 ^e	6,280.3 ^e
		20	45.8 ^a	82.4 ^a	6,575.4 ^f
Jan	3.5	25	44.0 ^a	120.4 ^c	7,091.7 ^g
		30	71.4 ^c	244.4 ⁱ	7,822.4 ^h
Feb	Less than 1.0	-	Na	Na	Na

Note: - Na: Due to the malfunctioning of the device, data has not been kept. The sifter can’t separate soil clods from cassava because the moisture is more than 25% and digger can’t function because moisture of soil is less than 1%.

- Average mean followed by the same letter vertically does not show a significant statistical difference. (P-value 0.05)

Most of cassava rhizomes are still under the ground. This type of condition will affect the operation of Conveyor Unit which is attached at the back. Therefore, the test was abandoned and the data has not been kept for this month. But in November, December and

January, the average moisture of soil is 12, 6, and 3.5% (wb), respectively. The Digger can separate cassava rhizomes after digging and put them on the ground. Regarding the test in February, the moisture of soil is less than 1% (wb). The soil is quite hard so it's impossible for the digger to penetrate in the soil. It can only grate the soil surface. Therefore, the data has not been kept for this month.

The hypothesis of the study has found that if digger can break soil clods into small pieces and place the cassava on the ground after the excavation, this condition will help the bucket to scoop cassava rhizomes from the ground. Therefore, in this study, sizes of soil clods have been measured by 2 values: the percentage of soil clods that are bigger than 75mm. and average size of soil clod (mm.). The results of the analysis of the sizes of soil clods after excavation (Tables 2 - 3) has found that reducing the angle of digger when soil moisture is between 3.5 - 12.0% (wb) will make the soil clods smaller after digging while soil clods which are bigger than 75 mm. also show a statistically significant decrease in amount (P-value 3.03^{-06} - Table 2). The average size of the soil clods has also decreased statistically (P-value 2.04^{-12} - Table 3). The percentages of soil clods which are bigger than 75 mm show no difference in amount for the operation while the soil has that kind of moisture.

From the observation, it has been shown that after digging the soil clods have become smaller in size. Cassava rhizomes after excavation will float more from the ground because the sifter that is attached at the back of the digger can separate larger amounts of soil from the cassava rhizome before they fall on the ground behind the sifter.

Table 2. The ANOVA analysis of the percentage of soil clods bigger than 75 mm. at the soil moisture and the digging angle at different levels

Source of Variation	SS	df	MS	F	P-value	
Soil Moisture Content	55.35	2	27.68	0.73	4.97^{-01}	ns
Share Angle	2,131.64	2	1,065.82	27.94	3.03^{-06}	**
Interaction	286.08	4	71.52	1.87	1.59^{-01}	ns
Within	686.75	18	38.16			
Total	3,159.82	26				

Table 3. The ANOVA analysis of soil in average size at the soil moisture and the digging angle at different levels

Source of Variation	SS	df	MS	F	P-value	
Soil Moisture Content	8,083.74	2	4,041.87	21.70	1.60^{-05}	**
Share Angle	63,368.11	2	31,684.07	170.10	2.04^{-12}	**
Interaction	7,147.18	4	1,786.80	9.60	2.00^{-04}	**
Within	3,352.78	18	186.27			
Total	81,951.80	26				

Analysis of the results for the draft force of the digger (Table 4) has found that reducing angle of digger will also reduce the draft force statistically (P-value 1.79^{-19}). From the results of tests above, the conclusion is to use digger angle at 20 degrees because this angle will cause the fewest numbers of soil clods that are bigger than 75 mm. (44.6% of soil total weight) and will also cause the size of soil clods to become smaller (69.0 mm.) This condition directly affects the ability to scoop the cassava rhizomes and reduce the hitting of

the tip of the bucket to the soil clods. The sparse bucket that is designed to separate soil clods from the cassava rhizome can also reduce the weight in conveying.

Table 4. The ANOVA analysis of draft force at soil moisture and digging angle in 3 levels

Source of Variation	SS	df	MS	F	P-value	
Soil Moisture Content	25,603,403.00	2	12,801,701.00	2,811.90	3.43 ⁻²³	**
Share Angle	9,839,362.00	2	4,919,681.00	1,080.57	1.79 ⁻¹⁹	**
Interaction	649,708.90	4	162,427.21	35.68	2.50 ⁻⁰⁸	**
Within	81,951.36	18	4,552.85			
Total	36,174,425.00	26				

3.2 Result of Test for the Function of Cassava Conveyor Unit

Due to the limitation of soil moisture content, testing for Digging and Preparing Unit could only be done in November, December and January as mentioned in 3.1 Therefore the result of the functional test for cassava Conveyor Unit is available for three months (Table 5).

Table 5. The results of cassava scooping when the soil moisture content and the digging angles were varied at 3 levels with the bucket speed at 6 levels.

Month	Soil moisture content (%wb)	Speed of bucket (m/s)	% of the amount of cassava rhizomes were successfully scooped on each angle of digging share (degree)		
			20	25	30
Oct	More than 25	-	Na	Na	Na
		0.5	100.0 ^a	56.7 ^a	Na
		1.0	98.9 ^a	46.7 ^{bc}	Na
Nov	12	1.5	98.9 ^a	36.7 ^{de}	Na
		2.0	77.8 ^b	22.2 ^f	Na
		2.5	Na	Na	Na
		3.0	Na	Na	Na
		0.5	100.0 ^a	50.0 ^{abc}	Na
Dec	6	1.0	100.0 ^a	43.3 ^{cd}	Na
		1.5	97.8 ^a	30.0 ^e	Na
		2.0	76.7 ^b	Na	Na
		2.5	Na	Na	Na
		3.0	Na	Na	Na
Jan	3.5	0.5	100.0 ^a	53.3 ^{ab}	Na
		1.0	100.0 ^a	46.7 ^{bc}	Na
		1.5	97.8 ^a	36.7 ^{de}	Na
		2.0	73.3 ^b	Na	Na
Feb	Less than 1	2.5	Na	Na	Na
		3.0	Na	Na	Na
		-	Na	Na	Na

Note: Na: Device could not operate, so no data needed to be kept. When the moisture content is more than 25% (wb) the bucket can't separate soil clods from cassava. When the moisture content is less than 1% (wb), the digger can't dig. The bucket speed at 2-3 m.lsec. causes severe bouncing.

Therefore, the data did not need to be kept.

- Percentage of scoop, followed by the same letter vertically shows no significant statistical difference.

In testing the Conveyor Unit, it has been found that when the speed of the bucket is increased to 2.5 m/s. The tip of the bucket will hit soil clods or cassavas so hard that the cassavas can be thrown out of the bucket before being conveyed from the ground. Therefore the test was abandoned and the data has not been kept because of speed problem. While the bucket that can operate at the speed of 0.5–1.5 m/s.

The results of the analysis regarding the achievement in conveying cassavas from the ground to drop into the collecting trailer if the bucket speed is 0.5-1.5 m/s. and digging angle is 20-25 degrees are shown in Table 6. When bucket speed is reduced, conveying is statistically more successful (P-value 1.62^{-05}). Increasing digging angle will decrease the amount of cassavas that can be conveyed statistically (P-value 1.99^{-15}). Increasing the digging angle during excavation will make the soil clods become bigger. (See more details from result of study in section 3.1).

Low bucket speeds help in collecting cassava better. However, while the bucket moves to the collecting trailer, the speed of movement must be enough to create the momentum to throw the cassava out of the bucket onto the collecting trailer that is attached at the back. Using lower speeds always cause the problem of the cassava rhizomes being dropped before they reach the collecting trailer. Therefore, bucket speed should be fast enough to scoop the cassava from the ground and should be able to create the momentum to throw cassava into the collecting trailer. Results from the tests have found that the bucket speed should not be higher than 1.5 m/s.

Table 6. The ANOVA analysis of the amount of cassava that can be conveyed, the bucket speed and the digging angle at different levels

Source of Variation	SS	df	MS	F	P-value	
Bucket speed	326.28	2	163.14	31.73	1.62^{-05}	**
Share Angle	13,519.16	1	13,519.16	2,629.62	1.99^{-15}	**
Interaction	218.85	2	109.42	21.28	1.13^{-04}	**
Within	61.69	12	5.14			
Total	14,125.98	17				

3.3 Result of Compatibility Test between Cassava Digger and Conveyor Units

From the factor test above, adjustments are needed for the functioning of the prototype Cassava Digger and Conveyor Units. The test operates in bed size of 5 x 80 m. The tests have shown that the prototype device can dig and collect cassava rhizomes continuously along the length of the 80 m bed. The working capacity is 0.05 ha/hr. The working efficiency in functioning is 59.10%. No losses have been found for cassava that has not yet been excavated, but the average losses of the cassava that has not yet been conveyed amounts to 3.23%.

4. CONCLUSIONS

From the functional test of Cassava Digging and Preparing Unit and Conveyor Unit that were designed and developed in this research, it has been found to have the ability to solve the problem in collecting and conveying cassavas. Digging and Preparing Unit should have digging angle at 20 degrees with both opaque side walls and attach sifter at the back of the

digger. This can help break soil clods after the excavation and put the cassavas on the ground. This is a significant condition that helps the bucket to collect cassavas. Cassava Conveyor Unit is designed in sparse bucket form. The best speed to continuously collect cassava from the ground should not be more than 1.5 m/s. so that it will not cause bouncing and can create enough momentum to throw cassava from the bucket into the collecting trailer. From the compatibility test of both prototypes, the average working capacity is 0.05 ha/hr. The working efficiency in functioning and the losses caused from conveying are 59.10 and 3.23 percent, respectively. Losses from excavation were not found.

Results from the study and the development of both prototype devices will help to develop a prototype of the Cassava Harvester Machine.

ACKNOWLEDGEMENT

This study was supported by The Postharvest Technology Innovation Center: Khon Kaen University and Agricultural Machinery and Postharvest Technology research Center, Khon Kaen University.

COMPETING INTERESTS

Authors have declared that no competing interests exist.

REFERENCES

- Food and Agriculture Organization of the United Nations. [online] (2011). [Cited 2011 October 9]. Available from: www.FAO.org.
- Mongkhontanathat, J., Chamsing, A. (2007). Cassava Digger, *Kasikhon*, 80(5), 89–102.
- Odigboh, E.U., Ahmed, S.F. (1982). A Cassava harvester: design analysis and prototype development. *Agricultural Mechanization in Asia Africa and Latin America*, 13(3), 40–48.
- Odigboh, E.U., Moreira, C.A. (2002a). Development of a complete cassava harvester: i - conceptualization. *Agricultural Mechanization in Asia, Africa and Latin America*, 33(4), 43–49.
- Odigboh, E.U., Moreira, C.A. (2002b). Development of a Complete Cassava Harvester: II - Design and Development of the Up roter/Lifter System, *Agricultural Mechanization in Asia, Africa and Latin America*, 33(4), 50–58.
- Regional Network for Agricultural Machinery. (1995). *RNAM Test Codes and Procedures for Farm Machinery*. Second ed., Bangkok.
- Siamwala, A. (2004). Dawn of agricultural sector: past and future of Thai countryside, paper presented in retrospective and prospective: twenty years of Thai Society and Economy, Chonburi, Thailand.
- Sukra, A.B. (1969a). Design and performance of a tractor-mounted cassava root digger. (MARDI Report No.181). Agricultural Research and Development Institute. Kuala Lumpur.
- Sukra, A.B. (1969b). Performance of API cassava root digger elevator. (MARDI Report No.187). Agricultural Research and Development Institute. Kuala Lumpur.